

STATUS SCIENTIFIC CONTROLS

Issue: 1

Date: 16.02.2010

Firmware: V1.3.3PR



Installation, Commissioning & Routine Gas Testing Manual

Gas Detector Type FGD10A

Flammable Gases

(‘Pellistor’ Gas Sensor)

(Relay version)

STATUS SCIENTIFIC CONTROLS

STATUS



SCIENTIFIC

ISO 9001:2000

Certificate No. GB93/1938

Status Scientific Controls Ltd

Hermitage Lane Industrial Estate,
Kings Mill Way, Mansfield,
Nottinghamshire, England.
NG18 5ER

www.status-scientific.com

Manufacturer's EC Declaration of Conformity

We declare, under our sole responsibility, that we believe the products identified in this declaration, and to which this declaration relates are in conformity with the requirements of the following Council Directives:

- 89/336/EEC as amended by 92/31/EEC on the approximation of the laws of the Member States relating to Electromagnetic Compatibility.
- 94/9/EC on the approximation of the laws of the Member States concerning equipment and protective systems intended for use in potentially explosive atmospheres.

Description of Equipment:

The FGD10 Series of Fixed Gas Detectors for the detection of Oxygen, Toxic or Flammable gases.
ATEX Flameproof Certified for use in Group IIC hazardous locations.

Standards applied:

Electrical apparatus for explosive gas atmospheres -General requirements.	EN60079-0:2006
Electrical apparatus for explosive gas atmospheres -Flameproof enclosure 'd'.	EN60079-1:2007
Electromagnetic compatibility - Electrical apparatus for the detection and measurement of combustible gases, toxic gases or oxygen.	EN50270:2006
Electromagnetic compatibility. Generic emission standard. Industrial environment.	EN61000-6-4:2007
Electromagnetic compatibility. Generic standards. Immunity standard for industrial environments.	EN61000-6-2:2005

Notified Body for Hazardous Area Certification:

SIRA Certification Service
Rake Lane, Ecclestone,
Chester, CH4 9JN.
Notified Body Number : 0518

Notified Body for ATEX Quality Assurance Notification:

Baseefa
Rockhead Business Park
Staden Lane, Buxton SK17 9RZ, UK
Notified Body Number : 1180

Product Hazardous Area Certificate Number:

SIRA 08ATEX1031X

ATEX Quality Assurance Notification Number:

2056

Place of Manufacture:

Mansfield, Nottinghamshire, UK. Date mark applied – see product

ISO 9001:2000 Quality Management System:

Certificate No. GB93/1938

Authorised Signatory to this declaration, on behalf of the manufacturer:

Name: W. R. Baxter Title: Managing Director

Address: Status Scientific Controls Ltd, Hermitage Lane Industrial Estate, Kings Mill Way
Mansfield, Nottinghamshire, NG18 5ER, United Kingdom

Signature

Date: 27.3.08.

Tel : +44 (0)1623 651381

Fax : +44 (0)1623 421063

e-mail : sales@status-scientific.com

STATUS SCIENTIFIC CONTROLS

Installation, Commissioning & Routine Gas Testing
FGD10A Flammable (Pellistor) Gas Detector



CONTENTS

1.	FIRMWARE REVISION	6
2.	PACKAGE CONTENTS	8
3.	SCOPE OF THE MANUAL	8
4.	DESCRIPTION	9
4.1.	RELAYS.....	11
4.2.	ALTERNATIVE GAS TYPES.....	11
5.	INSTALLATION	12
5.1.	CABLE ENTRIES	13
5.2.	MOUNTING AND TERMINAL ACCESS.....	13
5.3.	FGD10A CONNECTIONS	15
5.4.	POWER SUPPLY	16
5.5.	ANALOGUE OUTPUT.....	16
5.6.	RS232 OUTPUT	16
6.	COMMISSIONING	17
6.1.	APPLYING POWER.....	17
6.2.	INDICATORS	17
7.	INITIAL GAS TESTING	18
7.1.	ZERO GAS	18
7.2.	TEST GAS.....	20
7.2.1.	Gas connection points.....	20
7.2.2.	Sampling time	21
7.2.3.	Suggested calibration gas levels.....	21
8.	SOFTWARE FEATURES	22
8.1.	MENU MODE SELECTION	23
8.1.1.	E : 1 – Sensor Zero.....	24
8.1.2.	E : 2 – Sensor Span.....	24
8.1.3.	E : 3 – Sensor FSD.....	24
8.1.4.	E : 4 – Output Zero (4mA).....	24
8.1.5.	E : 5 – Output Span (20mA).....	24
8.1.6.	E : 6 – Decimal Places.....	24
8.1.7.	E : 7 – Firmware Version.....	25
8.1.8.	E : 8 – Sensor Selection.....	25
8.1.9.	E : 9 – Engineer diagnostics.....	26
8.1.10.	E : 12 – Cross reference	26
8.1.11.	E : 13 – Relay 1	27
8.1.12.	E : 14 – Relay 2	27
8.1.13.	E : 15 – Alarm Level 1.....	28
8.1.14.	E : 16 – Alarm Level 2.....	28
8.1.15.	E : 19 – Positive Zero Suppression	29
8.1.16.	E : 20 – Negative Zero Suppression.....	29
8.1.17.	E : 27 – Hysteresis.....	29
8.1.18.	E : 28 – Firmware update.....	30

STATUS SCIENTIFIC CONTROLS

Installation, Commissioning & Routine Gas Testing
FGD10A Flammable (Pellistor) Gas Detector



8.1.19.	<i>E : 29 – Relay 3</i>	30
8.1.20.	<i>E : 30 – Password</i>	31
8.1.21.	<i>E : 31 – Warm-up timer</i>	31
9.	CALIBRATION	32
9.1.	SENSOR CALIBRATION	32
9.1.1.	<i>Sensor Zero</i>	32
9.1.2.	<i>Sensor Span</i>	33
9.2.	ANALOGUE OUTPUT CALIBRATION	34
9.2.1.	<i>Analogue Output Zero</i>	35
9.2.2.	<i>Analogue Output Span</i>	35
10.	ERROR CODES	36
11.	COMMUNICATIONS PROTOCOL	37
11.1.	HARDWARE CONNECTIONS	37
11.2.	CONTROL BYTE CONSTANTS	37
11.3.	FRAME STRUCTURE	38
11.4.	VARIABLES	38
11.5.	READING A VARIABLE	39
11.5.1.	<i>Read example - read live data</i>	40
11.6.	WRITING A VARIABLE	41
12.	ROUTINE GAS TESTING	42
13.	SENSOR REPLACEMENT	43
13.1.	FLAMMABLE (PELLISTOR) SENSOR	43
14.	FUSES	52
15.	SPECIFICATION	53
16.	DIMENSIONS	54
17.	CERTIFICATION	55

STATUS SCIENTIFIC CONTROLS

Installation, Commissioning & Routine Gas Testing
FGD10A Flammable (Pellistor) Gas Detector



1. FIRMWARE REVISION

V1.3.3xy 17th Feb 2010

Menu system feature adjusted to reflect manual and be consistent throughout gas types

V1.3.2xy 21st Jan 2008

Menu system feature removed - MENU 21, never been implemented

V1.3.1xy 24th Oct 2007

Menu system feature added - MENU 49 program brown out fuse to operate at 4.2V was 2.0V.

V1.3.0xy 12th May 2005

Menu system can be entered by UP or DOWN keys when the password system is set to OFF, bug fixed.

V1.2.9xy 24th Feb 2005

E5 defaults to 350 - should be 850
default alarms for Flamm were 25:50
change to 20:40

V1.2.8xy 14th Feb 2005

bug in autozero code: not cleared during zero cal - fixed.

V1.2.7xy Jan 2005

Internal use

V1.2.6xy 28th Jan 2005

Fault code for IR variant changed to 50% of signal at zero cal: previous version did not guarantee fault condition.

V1.2.5xy 25th Jan 2005

Version to include all FGD9 variants:
MK1 & MK2.
Infrared, Toxic, Pellistor.

V1.2.4x 25th Jan 2005

Version 1.2.3r skipped - temp version for relay 3 menu option bug fix.
one version of code for Mk1 & Mk2 IR hardware.
Auto zero code added: activated by setting Pos & Neg zero suppression to 1.

V1.2.3x 2nd Dec 2004

P2P code change as per MK3OEM

V1.2.2x 24th Jan 2005

Infrared sensor types changed: using temperature compensated pyros from now on.

STATUS SCIENTIFIC CONTROLS

Installation, Commissioning & Routine Gas Testing

FGD10A Flammable (Pellistor) Gas Detector



V1.2.1x 3rd Aug 2004

Bug fix in fault relay code: now implemented.

Bug in relay menu: relay 2 only shows E:r after change - fixed

V1.2.0x 3rd June 2004

Incorporate features of MK2 OEM firmware version 3.1.0

Add password control for menu structure:

No password give access to subset menu, ie 1,2

Valid password gives access to full menu structure

Version x - ' ' standard code - no relays 'r' relays operate

V1.1.0 27th May 2004

Allow editing of temp comp factors via menu for Shell tests

V1.0.1 12th Jun 2003

LCD code changed - saves about 400 program words

V1.0.0 24th Jan 2003

Code released for general use.

STATUS SCIENTIFIC CONTROLS

Installation, Commissioning & Routine Gas Testing

FGD10A Flammable (Pellistor) Gas Detector



2. PACKAGE CONTENTS

The FGD10A is supplied in a box containing the following items:-

Description	Stock No
FGD10A Flammable (Pellistor) Gas Detector	SS709 - *
Magnetic pen	SS840
Installation manual	
Calibration certificate	

Optional:-

Weather guard	SS749
---------------	-------

* Stock No. SS709 is followed by a suffix indicating the target gas for which the detector has been factory calibrated as shown below. There are no constructional differences between the types – all use the same version of pellistor sensor.

- 0 = Hydrogen
- 1 = Methane
- 2 = Ethane
- 3 = Propane
- 4 = Butane
- 5 = Pentane
- 6 = Hexane
- 7 = Nonane
- 8 = Ethylene
- 9 = Toluene

To order a replacement 'pellistor' sensor, quote Stock No. SS294.

3. SCOPE OF THE MANUAL

This manual relates specifically to the version of the FGD10A gas detector with the following features:-

- A pellistor type sensor for the detection of a wide range of flammable gases including Methane and Hydrogen.
- Output signals in the form of 4 to 20mA and RS232 communications.
- Three control relays each fitted with a single set changeover contacts.

STATUS SCIENTIFIC CONTROLS

Installation, Commissioning & Routine Gas Testing
FGD10A Flammable (Pellistor) Gas Detector



4. DESCRIPTION



FGD10A GAS DETECTOR



**FGD10A GAS DETECTOR FITTED WITH
PROTECTIVE WEATHERGUARD**

STATUS SCIENTIFIC CONTROLS

Installation, Commissioning & Routine Gas Testing

FGD10A Flammable (Pellistor) Gas Detector



The FGD10A is an explosion protected ATEX and IECEx certified fixed gas detector for use in potentially explosive atmospheres. The unit may be optionally fitted with a protective weather guard as shown in the photograph.

IMPORTANT – When used in hostile environments (e.g. oil platforms where the instrument is exposed to salt spray or diesel) it is recommended that the FGD10A is always fitted with its protective weather guard. The weather guard is attached with tamperproof screws to ensure that it is not inadvertently removed.

The unit comprises an instrument housing having two cable gland entries and containing the connection terminals, electronics and display window.

The housing containing the gas sensor has an M27 thread and is screwed into the bottom of the unit. The sensor housing itself is a certified component and must not be removed in service.

Behind the display window are:-

- A 4-digit LCD display
- Four magnetically operated switches that are activated through the display window using a magnetic pen that is supplied with the unit.
- LED indicators for POWER, ALARM & KEY PRESS

The magnetically operated switches allow the unit to be calibrated whilst power is still applied without the need to remove the cover from the unit.

The main electrical features of the unit are:-

- Power supply – 8 to 24 volts dc (non-intrinsically safe)
- Analogue output – 4 to 20mA dc
- RS232 communications output.
- Relay contact outputs for Alarm 1, Alarm 2 and Fault.
- Gland entry threads available – 20mm, ½” or ¾” NPT



4.1. Relays

The FGD10A relay version has 3 factory-fitted relays. Each provides a set of voltage free changeover contacts to perform the following control functions:-

- Alarm Level 1
- Alarm Level 2
- Fault

Versions without relays fitted are also available.

The self-adhesive label on the outer surface of the enclosure indicates whether or not the relays are fitted as shown below:-

**GAS DETECTOR TYPE FGD10
NO CONTROL RELAYS FITTED**

**GAS DETECTOR TYPE FGD10
CONTROL RELAYS FITTED**

4.2. Alternative gas types

Versions of the FGD10A are available for detection of other gases, fitted with any of the following sensor types:-

- Infrared (for detecting hydrocarbons and carbon dioxide)
- Toxic
- Oxygen



5. INSTALLATION

It is important that the correct cable and gland types are used when installing the FGD10A in a hazardous location.

The cable entry devices and blanking elements of unused apertures shall be of a certified flameproof type, suitable for the conditions of use and correctly installed.

With the use of conduit, a suitable certified sealing device such as a stopping box with compound shall be provided immediately at the entrance to the flameproof enclosure.

In order to prevent dangerous overloading of the FGD10A gas detector, it is important that the installer observes the relay contact rating and ensures that external circuits connected to the relay contacts are suitably protected from exceeding that rating and associated cabling is adequately rated and suitably installed.

Guidance on the correct installation of systems is provided by EN60079-14:2003. It is the responsibility of the installer to ensure compliance with the relevant standards.

To ensure effective gas detection, the FGD10A must be located at a height appropriate to the density of the target gas relative to air. For example, Methane (relative density 0.55) is lighter than air and so it will tend to accumulate at a high level within a confined space. Whereas Petroleum (relative density 2.8) is heavier than air and it will tend to accumulate at around ground level.

European standard EN 61779-1:2000 provides comprehensive flammability data (including relative density) on approximately 300 types of gases.



5.1. Cable entries

The cable entry threads are 20mm, ½” or ¾” NPT female.

The FGD10A enclosure is manufactured from die cast aluminium*. Therefore, the use of glands, conduit fittings and blanks made from brass should be avoided because if moisture is present, bi-metallic corrosion may occur due to the chemical reaction between the two materials.

Glands and fittings plated with nickel, tin or zinc will provide improved protection but in harsh environments the use of stainless steel is recommended.

When connecting the cores inside the unit it is beneficial to use pointed-nose pliers to carefully guide the cable cores from the cable entries at the rear of the enclosure towards the pcb mounted terminal connections situated near to the front of the enclosure.

* Stainless Steel versions are also available.

5.2. Mounting and terminal access

The FGD10A should be mounted and secured using the mounting holes on the main unit.

Figures 2 and 3 shows details of the FGD10A terminal connections – these can be accessed as follows:-.

1. Switch OFF the supply to the FGD10A.
2. Release the grub screw located near the lip of the enclosure cover.
Note: It is not necessary to completely remove the grub screw to release the enclosure front cover.
3. Remove the enclosure front cover by rotating it several times in an anti-clockwise direction.
4. Unplug the top display board from within the enclosure by pulling it forwards. The board is captivated by means of a nylon wire in order to prevent it falling from the unit –take care to ensure that the board is not damaged during installation. See Figure 1.
5. The terminals can now be accessed.

Store the front cover such that it cannot be damaged or the thread contaminated with dirt.

STATUS SCIENTIFIC CONTROLS

Installation, Commissioning & Routine Gas Testing
FGD10A Flammable (Pellistor) Gas Detector

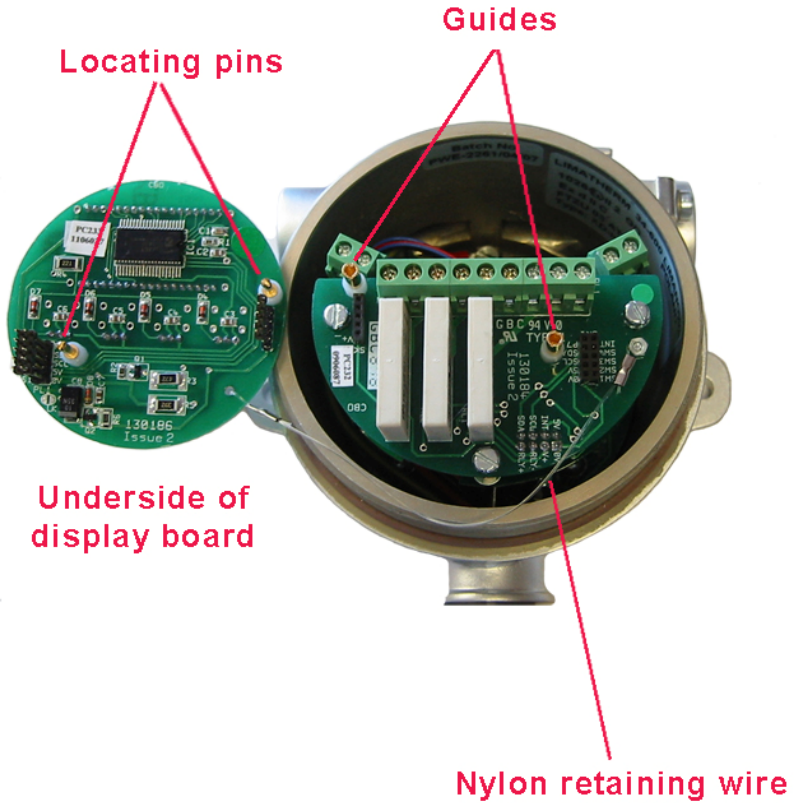

Figure 1 – Unplugging the display board for connection purposes

5.3. FGD10A connections

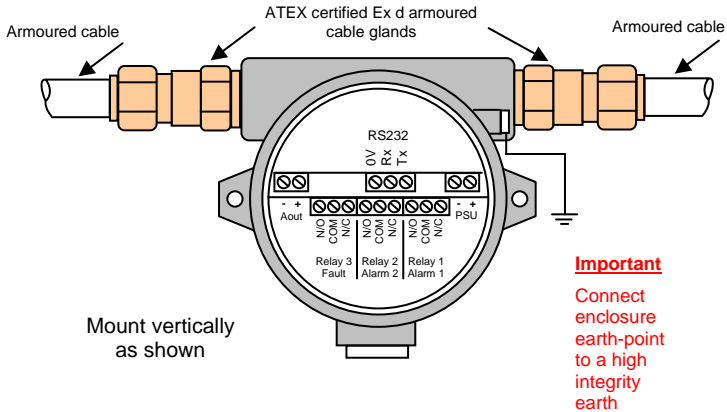

Figure 2 – Armoured Cable Gland Installation

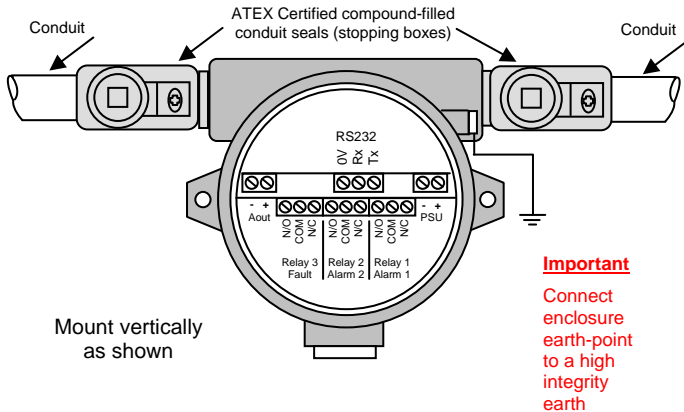

Figure 3 – EEx d Conduit Installation

5.4. Power Supply

The FGD10A is powered from an 8 – 24 volt dc, 5 W maximum output supply. This may be either:-

- An independent supply powering one or more units.
- A supply that is an integral part of a control card within a monitoring panel.

5.5. Analogue Output

The analogue output provides a means of indicating to external equipment (e.g. data loggers, remote displays, control cards) the gas levels currently being detected by the system. The output is in the form of the industry standard 4 to 20mA current source.

The analogue output is factory set such that 4mA represents zero gas and 20mA represents the full scale gas level of the FGD10A.

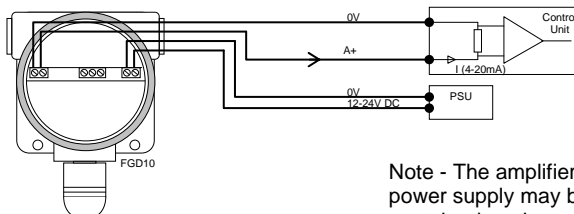

Note - The amplifier and power supply may be contained on the same control card.

Figure 4 – Analogue Output

5.6. RS232 Output

This output is designed to be compatible with a PC fitted with an RS232 serial communications port. Suitable software is available for installation in the PC. Contact Status Scientific Controls Ltd for details.

STATUS SCIENTIFIC CONTROLS

Installation, Commissioning & Routine Gas Testing
FGD10A Flammable (Pellistor) Gas Detector



6. COMMISSIONING

Following completion of the installation:-

- a) Replace the top display board using the locating pins on the underside of the board to ensure that it makes connection with the remainder of the electronics - see Figure 1.
- b) Ensure that the front cover has not been contaminated with dirt - paying particular attention to the thread. Replace the cover by rotating it several times clockwise until it reaches its limit then secure using the grub screw – do not over tighten.

6.1. Applying power

Once the installation is complete and the covers are secure then power can be applied. The power source should be between 8 and 24 volts dc.

When power is first applied to the FGD10A, an initialisation procedure is performed as follows:

All segments on the LCD are shown	:	8.8:8.8
The software version is displayed	:	1.3.0
The manufacturer code is displayed	:	SSCL
The sensor type is displayed	:	PELL

The detected gas level present is displayed and the FGD10A becomes operational.

6.2. Indicators

Three LED indicators are visible from the front panel of the instrument. These are:

Colour	Identity	Operation
Red	Alarm	Illuminates when either alarm level has been reached.
Green	Power	Always ON when power is connected.
Yellow	Key press	Illuminates when the magnetic switches are operated.



7. INITIAL GAS TESTING

FGD10A units are factory calibrated as detailed on the calibration certificate supplied with the instrument. However, it is always advisable after installation to confirm that the instrument reads zero with no gas present and responds accurately when presented with an appropriate concentration of the target gas.

The FGD10A display becomes operational within 60 seconds however, the sensor should be allowed to stabilise for the period specified on the associated calibration certificate before attempting to check the zero setting and gas response.

7.1. Zero gas

With no gas present check that the instrument reads zero on the display *.

- a) If the instrument reads zero then no adjustment is required and gas response testing may now be carried out as described in Section 7.2.
- b) If the instrument does not read zero then adjustment of the zero setting is required as described in Section 9.1.1. - Sensor Zero.
- c) If the analogue signal is connected to an associated control panel, confirm that when the FGD10A display reads zero, the control panel display also reads zero or, adjust as necessary in accordance with the control panel manufacturers' instructions.

** Note – If there is the possibility of a background gas being present then zeroing of the detector should be carried out using a test gas cylinder of air in nitrogen.*

STATUS SCIENTIFIC CONTROLS

Installation, Commissioning & Routine Gas Testing
FGD10A Flammable (Pellistor) Gas Detector



Figure 6 – Arrangement for Application of a Certified Test Gas

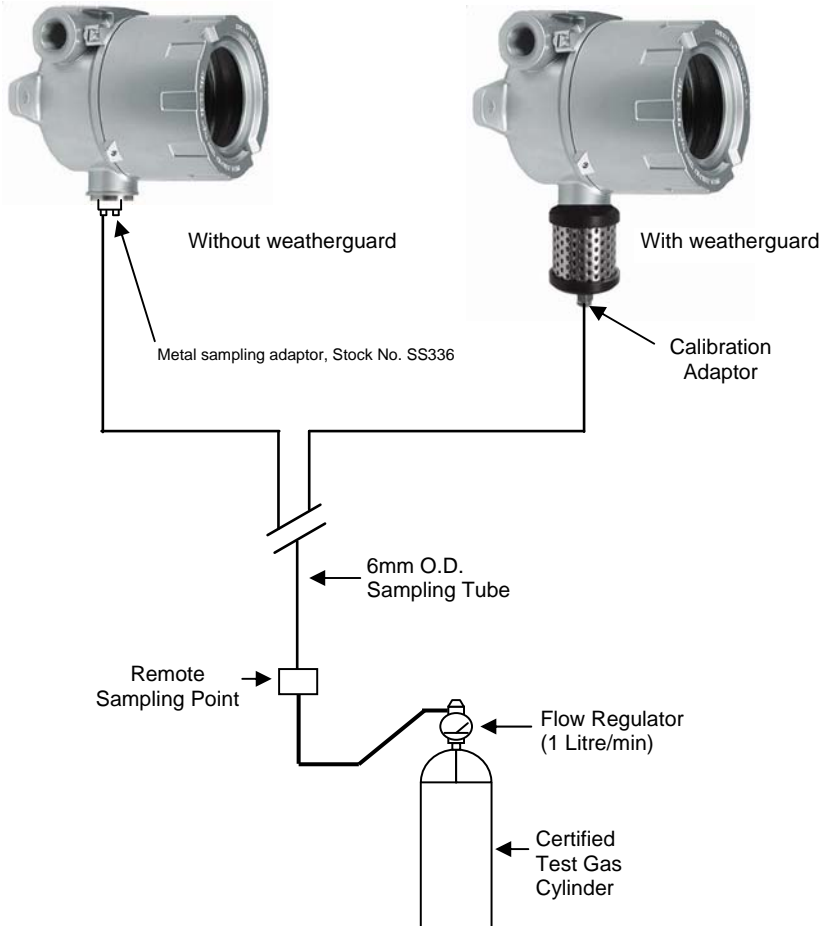



7.2. Test gas

Figure 6 shows a typical arrangement for the application of a certified test gas.

The purpose of the test gas response check is to confirm that that the reading on the instrument corresponds with the test gas concentration.

- a) If the instrument reads correctly then no adjustment is required.
- b) If the analogue signal is connected to an associated control panel, confirm that the reading corresponds with that on the FGD10A or adjust as necessary in accordance with the control panel manufacturer's instructions.
- c) If the above checks are satisfactory then the installation is now complete.
- d) If the instrument does not read correctly then adjustment of the sensor span setting is required as described in Section 9.1.2. - Sensor Span.

7.2.1. Gas connection points

Certified test gas can be applied either:-

- a). directly to the FGD10A via the appropriate sampling/calibration adaptor.

or

- b). remotely, by connecting a test gas sampling tube to the appropriate sampling/calibration adaptor and installing a test point at the remote end of the tube.

Method b) avoids the need to gain direct access to the unit in order to carry out routine gas testing. The sample tube should be taken to a convenient point and sited such that the risk of contamination is minimised. A means must be provided to 'cap off' the tube when not in use in order to prevent blockage.

The weather guard is provided with a 6mm O.D. push in tube connector to allow connection of a gas sampling tube. Firstly, remove the blanking plug by depressing the coloured plastic ring whilst pulling on the plug; now push in the gas sampling tube. The standard fitting is a push fit connector for 6mm

STATUS SCIENTIFIC CONTROLS

Installation, Commissioning & Routine Gas Testing

FGD10A Flammable (Pellistor) Gas Detector



O.D tubing. The connector is screwed into a 1/8" BSP thread; other fittings are available on request.

Where a weather guard is not fitted, the use of a sampling adaptor (Stock No. SS336) is required in order to present the gas to the FGD10A sensor.

7.2.2. Sampling time

Apply the test gas and allow a sufficient time for the sample to reach the gas detector. The response time will vary according to the length of the sampling tube.

7.2.3. Suggested calibration gas levels.

Flammable sensor 0-100%LEL (type PELL):

Zero gas free air (must contain oxygen).

Span 50%LEL balance air.

8. SOFTWARE FEATURES

The menu system featured within the FGD10A allows all calibration and configuration activities to be performed.

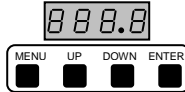

The magnetic keypad has the following functionality:

Button	Function	Alternate Function
MENU	Open / Close Menu	PASSword
UP	Next / Increase	1
DOWN	Previous / Decrease	2
ENTER	Accept selection	3

This section of the manual discusses how the available menu options can be accessed, how the associated parameter may be changed via the selected menu option and what effect the change to the parameter has on the operation of the FGD10A.

The FGD10A incorporates magnetically operated switches to allow non-intrusive operation of the menu system. To 'press' the switch requires movement of the stylus pen over the appropriate button. The key press LED will light to indicate that the button press is being detected. In some instances it may be necessary to hold the pen over the button for sufficient time to allow the microcontroller to determine the key that has been *pressed*.

Note:

It is important that that the FGD10A is correctly configured for the sensor in use, prior to performing any feature available in the menu system.

STATUS SCIENTIFIC CONTROLS

Installation, Commissioning & Routine Gas Testing
FGD10A Flammable (Pellistor) Gas Detector



8.1. Menu Mode Selection

The FGD10A uses a password system to restrict the end user from carrying out certain changes that may compromise the use of the equipment. Setting the password to zero will give the user access without compromise.

User password allows access to calibrate the sensor only.

Engineer password gives complete access and allows every aspect of the system to be changed.

Note : The password is a pre-set six digit number which can be obtained from Status Scientific Controls Ltd.

Several calibration modes exist in the FGD10A and these are accessible via the instruments simple menu system. To select a calibration mode follow this procedure:

- Press the MENU button, **E: 1** appears on the display.
- Press UP or DOWN until the required menu option is displayed.
- Press ENTER to select the calibration mode.
- To exit the menu press MENU.

While the instrument is in menu mode – any data displayed on the screen will alternate between the cal number and the reading.

The following features are available via the 'FGD10A' menu system: -

Menu Option	Section
E : 1 – Sensor Zero	8.1.1.
E : 2 – Sensor Span	8.1.2.
E : 3 – Sensor FSD	8.1.3.
E : 4 – Output Zero (4mA)	8.1.4.
E : 5 – Output Span (20mA)	8.1.5.
E : 6 – Decimal Places	8.1.6.
E : 7 – Firmware version	8.1.7.
E : 8 – Restore	Error! Reference source not found.
E : 9 – Engineer diagnostics	8.1.8.
E : 12 – Cross reference	8.1.9.
E : 13 – Relay 1	8.1.11.
E : 14 – Relay 2	8.1.12.
E : 15 – Alarm Level 1	8.1.13.
E : 16 – Alarm Level 2	8.1.14.
E : 19 – Positive Zero Suppression	8.1.15.
E : 20 – Negative Zero Suppression	8.1.16.
E : 27 – Hysteresis	8.1.17.
E : 28 – Firmware Update	8.1.18.

STATUS SCIENTIFIC CONTROLS

Installation, Commissioning & Routine Gas Testing
FGD10A Flammable (Pellistor) Gas Detector



E : 29 – Relay 3	8.1.19.
E : 30 – Password	8.1.20.
E : 31 – Warm-up timer	8.1.21.

8.1.1. E : 1 – Sensor Zero

Refer to section 9.1.1. for sensor calibration details.

8.1.2. E : 2 – Sensor Span

Refer to section 9.1.2. for sensor calibration details.

8.1.3. E : 3 – Sensor FSD

This menu option allows the full-scale gas level to be selected.

- From the menu system select menu option: **E: 3** and press ENTER.
- Using the INCREASE and DECREASE buttons; adjust the FSD to the required level.
- Press ENTER, '- - - 'will be displayed to indicate that the new setting has been accepted.

Note:

Pressing MENU instead of ENTER will exit the menu without changing the FSD.

- Press MENU to close the menu system.

8.1.4. E : 4 – Output Zero (4mA)

Refer to section 9.2.1. for output calibration details.

8.1.5. E : 5 – Output Span (20mA)

Refer to section 9.2.2. for output calibration details.

8.1.6. E : 6 – Decimal Places

The number of decimal places that are used to display the detected gas levels can be changed via this menu option.

- From the menu system select menu option: **E: 6** and press ENTER.
- Using the NEXT and PREVIOUS buttons, select the required number of decimal places.
- Press ENTER.

STATUS SCIENTIFIC CONTROLS

Installation, Commissioning & Routine Gas Testing
FGD10A Flammable (Pellistor) Gas Detector



Note: Pressing MENU instead of ENTER will exit the menu without changing the number of decimal places to which the gas level will be displayed.

- Press MENU to close the menu system.

Note that when the sensor type is first selected, the optimum number of decimal places for a given sensor type and range is automatically selected. Increasing the number of decimal places to which detected gas levels are displayed does not increase the sensitivity or accuracy of the instrument and in some cases may degrade the instruments perceived stability.

8.1.7. E : 7 – Firmware Version

The Firmware version is displayed in the form X.X.Xyy, where X is numerical and y is a letter.

- Press MENU to close the menu system.

8.1.8. E : 8 – Sensor Selection

This menu option allows the sensor type to be selected. The available sensor options are listed below:

OPTION	TYPE	RANGE	COMMENTS
PELL	Pellistor	0-100%LEL	General hydro carbons
tc1	Pellistor	0-100%Vol	Methane

The sensor type is selected as follows:

- From the menu system select menu option: E: 8 and press ENTER.
- Using the NEXT and PREVIOUS buttons, select the required sensor.
- Press ENTER.
Note: Pressing ENTER whilst in menu option E: 8 will reset the factory defaults for the displayed sensor. A calibration must be performed even if the sensor type was not changed.
- Press MENU to close the menu system.

Note: It is important that the sensor selected via this menu option corresponds to the sensor that is installed. Incorrect settings here may result in the inability of the instrument to detect gas.



8.1.9. E : 9 – Engineer diagnostics

This feature is a view-only feature. No configuration changes are possible from within this menu.

The information is for use of Status Scientific Controls personnel.

- From the menu system select menu option: **E: 9** and press ENTER.
- Using the NEXT button, display the required setting. The displayed values are as follows:
E : 90 Gas level
E : 93 Active sensor A to D counts
- Press MENU to close the menu system.

8.1.10. E : 12 – Cross reference

This option is used to allow the user to calibrate the sensor with a commonly available gas (e.g. methane or propane) but use the unit to detect a different gas (e.g. methanol or acetone etc.). This is achieved by adjusting the cross-reference factor according to the difference in signal that is detected for the calibration gas compared to the target gas.

- Select menu mode **E:12** and press ENTER.
- Using the UP and DOWN buttons set the required cross-reference factor as required.
- Press ENTER to store the new value, Pressing MENU instead of ENTER aborts the feature.
- Press MENU to return the instrument to its standard mode of operation.

Note: the default setting of 1.00 is used – no cross sensitivity to target gas.

Contact Status Scientific Controls Ltd for details.

STATUS SCIENTIFIC CONTROLS

Installation, Commissioning & Routine Gas Testing
FGD10A Flammable (Pellistor) Gas Detector



8.1.11. E : 13 – Relay 1

The unit is fitted with a relay that is operated in conjunction with the alarm level. The user can select if the relay is normally Energized, 'E' or normally de-energised, 'd' when the unit is **not** in an alarm condition.

- From the menu system select menu option: **E: 13** and press ENTER.
- The display will show the following:
 - E:r Normally energized, rising alarm
 - d:r Normally de-energized, rising alarm
 - E:F Normally energized, falling alarm
 - d:F Normally de-energized, falling alarm
- The mode of operation can be changed by pressing the UP button.
- Press ENTER to accept the new relay mode of operation.
Note: Pressing MENU instead of ENTER leaves the unit without change.
- Press MENU to return the instrument to its standard mode of operation.

8.1.12. E : 14 – Relay 2

The unit is fitted with a relay that is operated in conjunction with the alarm level. The user can select if the relay is normally Energized, 'E' or normally de-energised, 'd' when the unit is **not** in an alarm condition.

- From the menu system select menu option: **E: 14** and press ENTER.
- The display will show the following:
 - E:r Normally energized, rising alarm
 - d:r Normally de-energized, rising alarm
 - E:F Normally energized, falling alarm
 - d:F Normally de-energized, falling alarm
- The mode of operation can be changed by pressing the UP button.
- Press ENTER to accept the new relay mode of operation.
Note: Pressing MENU instead of ENTER leaves the unit without change.
- Press MENU to return the instrument to its standard mode of operation.

STATUS SCIENTIFIC CONTROLS

Installation, Commissioning & Routine Gas Testing
FGD10A Flammable (Pellistor) Gas Detector



8.1.13. E : 15 – Alarm Level 1

The gas level that will cause Relay 1 to change state is set via this menu option.

- From the menu system select menu option: **E: 15** and press ENTER.
- Using the UP and DOWN buttons, adjust the displayed reading so that it matches the desired alarm set point.
- Press ENTER to accept the new alarm level.
Note: Pressing MENU instead of ENTER aborts the feature.
- Press MENU to return the instrument to its standard mode of operation.

8.1.14. E : 16 – Alarm Level 2

The gas level that will cause Relay 2 to change state is set via this menu option.

- From the menu system select menu option: **E: 16** and press ENTER.
- Using the UP and DOWN buttons, adjust the displayed reading so that it matches the desired alarm set point.
- Press ENTER to accept the new alarm level.
Note: Pressing MENU instead of ENTER aborts the feature.
- Press MENU to return the instrument to its standard mode of operation.



8.1.15. E : 19 – Positive Zero Suppression

This option is used to allow the user to suppress small amounts of positive sensor zero drift. The setting can be set between 0 and 10% of the sensor range as set by the FSD value.

- Press MENU to open the menu system.
- Using the NEXT and PREVIOUS buttons, select menu option:
E:19
- Press ENTER.
- Using the INCREASE and DECREASE buttons, set the required zero suppression value.
- Press ENTER to store the new value.
Note: Pressing the MENU button rather than the ENTER button exits without any change.
- Press MENU to close the menu system.

8.1.16. E : 20 – Negative Zero Suppression

This option is used to allow the user to suppress small amounts of negative sensor zero drift. The setting can be set between 0 and 10% of the sensor range as set by the FSD value.

- Press MENU to open the menu system.
- Using the NEXT and PREVIOUS buttons, select menu option:
E:20
- Press ENTER.
- Using the INCREASE and DECREASE buttons, set the required zero suppression value.
- Press ENTER to store the new value.
Note: Pressing the MENU button rather than the ENTER button exits without any change.
- Press MENU to close the menu system.

8.1.17. E : 27 – Hysteresis

This option sets the alarm hysteresis. The relays will chatter if this level is set to 100.

95% is the usual setting for pellistor sensors.

STATUS SCIENTIFIC CONTROLS

Installation, Commissioning & Routine Gas Testing
FGD10A Flammable (Pellistor) Gas Detector



8.1.18. E : 28 – Firmware update

Use this menu option to place the FGD10A module in the programming mode whereby the internal firmware can be updated.

- Press the MENU to open the menu system.
- Using the NEXT and PREVIOUS buttons, select menu option: **E:28**
- Press ENTER.
- The display shows **prog**
- Press the MENU button. The displays shows **boot**

Note: the only way to exit out of this mode is to either remove the power or program the device from the PC software.

See PC software manual to carry out the actual programming of the FGD10A module.

8.1.19. E : 29 – Relay 3

The unit is fitted with a relay that is operated in conjunction with a fault condition. The user can select if the relay is normally Energized, 'E' or normally de-energized, 'd' when the unit is **not** in a fault condition.

- From the menu system select menu option: **E: 29** and press ENTER.
- The display will show the following:
 - E:r Normally energized, rising alarm
 - d:r Normally de-energized, rising alarm
 - E:F Normally energized, falling alarm
 - d:F Normally de-energized, falling alarm
- The mode of operation can be changed by pressing the UP button.
- Press ENTER to accept the new relay mode of operation.
Note: Pressing MENU instead of ENTER leaves the unit without change.
- Press MENU to return the instrument to its standard mode of operation.

STATUS SCIENTIFIC CONTROLS

Installation, Commissioning & Routine Gas Testing
FGD10A Flammable (Pellistor) Gas Detector



8.1.20. E : 30 – Password

Use this menu option to enable / disable the password feature.
Place the FGD10A in the password menu as follows:

- Press the MENU to open the menu system.
- Using the NEXT and PREVIOUS buttons, select menu option: **E:30**
- Press ENTER.
- The display shows either **On** or **OFF**
- Press the UP button to select the desired setting.
- Press ENTER to accept the setting.
Note: Pressing MENU instead of ENTER leaves the unit without change.
- Press MENU to return the instrument to its standard mode of operation.

Note: if the password is in operation then the user will be prompted with PASS when ever the menu key is pressed. Pressing the MENU key again will result in the restricted user access, i.e. only the zero and span options will be available. Entering the correct password will give access to the full menu facility.

8.1.21. E : 31 – Warm-up timer

The sensor goes through a stabilisation period when power is first applied. This option allows the user to adjust the time that is applied before readings are displayed / transmitted.

- From the menu system select menu option: **E: 31** and press ENTER.
- Using the INCREASE and DECREASE buttons, set the required warm-up time.
- Press ENTER to store the new value.
Note: Pressing the MENU button rather than the ENTER button exits without any change.

Pellistors normally warm up in a few seconds.

STATUS SCIENTIFIC CONTROLS

Installation, Commissioning & Routine Gas Testing
FGD10A Flammable (Pellistor) Gas Detector



9. CALIBRATION

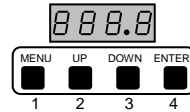

9.1. Sensor Calibration

This feature allows the sensor to be calibrated. Ensure that the correct sensor type is selected in the configuration prior to calibration. Refer to section 8.1. for details of the menu system operation.

Note: if the password is in operation then the user will be prompted with PASS when ever the menu key is pressed. Pressing the MENU key again will result in the restricted user access, i.e. only the zero and span options will be available. Entering the correct password will give access to the full menu facility.

9.1.1. Sensor Zero

- From the menu system select menu option: **E: 1** and press ENTER.
- Ensure the sensor is in a zero-gas environment.
Note: Where a purging gas has to be applied, use a flow rate of between 500 and 1000cc/min. Allow sufficient time for the sensor to respond.
- Press ENTER to zero the sensor, '---' will be displayed to confirm the sensor zero has been performed.
Note: Pressing MENU rather than ENTER exits the zero feature without performing the calibration.
- Press MENU to close the menu system.
Note: The ZERO factor will be displayed momentarily on exit.



9.1.2. Sensor Span

Always zero the sensor prior to performing a span operation.

- From the menu system select menu option: **E: 2** and press ENTER.
- Apply a known concentration of gas (applicable to sensor type) at a flow rate of between 500 and 1000cc/min. Allow time for the sensor to respond.
- Using the UP and DOWN buttons, set the reading to that of the calibration gas level.
- Press ENTER to span the sensor; '---' will be displayed to confirm the sensor span has been performed.
Note: pressing MENU rather than ENTER exits the span feature without performing the calibration.
Wait until the reading is stable; if necessary press ENTER again to span the sensor.
- Press MENU to close the menu system.
Note: the SPAN factor will be displayed momentarily on exit.
- Turn off and disconnect the calibration gas.



9.2. Analogue Output Calibration

The analogue output is that of a current source. In order to calibrate the output it is necessary to monitor the output signal. This can be performed in one of two ways:

Current measurement:

Connect an ammeter (or multimeter set to measure current in the mA range) in series with the analogue output.

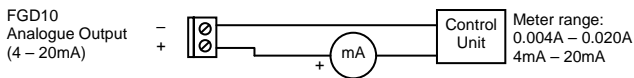

Advantage: Direct measurement of output.

Disadvantage: The analogue output has to be disconnected to allow the connection of the meter.

Voltage measurement:

Permanently connect a 10R resistor in series with the analogue output. When calibration is required, connect a voltmeter (or multimeter set to measure voltage in the mV range) across the 10R resistor.

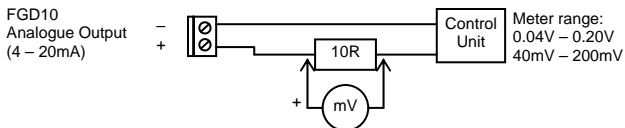

Advantage: No need to disturb wiring between FGD10A and control unit.

Disadvantage: Measurement accuracy dependent upon resistor tolerance.



9.2.1. Analogue Output Zero

- Monitor the current sourced from the analogue output of the FGD10A using a suitable method.
- From the menu system select menu option: **E: 4** and press ENTER.
- Using the INCREASE and DECREASE buttons; adjust the output to the required level (4mA or 40mV).
- Press ENTER.

Note: Pressing the MENU button rather than the ENTER button exits the zero feature without performing the calibration.

- Press the MENU button to close the menu system.

Note: The ZERO factor will be displayed momentarily on exit.

9.2.2. Analogue Output Span

Always zero the analogue output prior to performing a span operation.

- From the menu system select menu option: **E: 5** and press ENTER.
- Using the INCREASE and DECREASE buttons; adjust the output to the required level.
- Press ENTER button.

Note: Pressing the MENU button rather than the ENTER button exits the span feature without performing the calibration.

- Press the MENU button to close the menu system.

Note: The ANALOGUE OUTPUT SPAN factor will be displayed momentarily on exit.

STATUS SCIENTIFIC CONTROLS

Installation, Commissioning & Routine Gas Testing

FGD10A Flammable (Pellistor) Gas Detector



10. ERROR CODES

Not applicable to the Pellistor FGD10 variant



11. COMMUNICATIONS PROTOCOL

The communications protocol used by the FGD10A is used for communications between devices connected via an RS232 connection at 19200 baud, 8 data bits 1 stop bit, no parity. This point-to-point, P2P, protocol is a frame-based protocol.

11.1. Hardware connections

PC 9-way 'D' connector FGD10A connection

2	Tx
3	Rx
5	0V

PC 25-way 'D' connector FGD10A connection

3	Tx
2	Rx
7	0V

11.2. Control Byte Constants

The following control byte constants are used in the P2P protocol¹.

Read,	RD	=	0x13	(00010011)
Data Link Escape,	DLE	=	0x10	(00010000)
Write,	WR	=	0x15	(00010101)
Acknowledge,	ACK	=	0x16	(00010110)
Negative Acknowledge,	NAK	=	0x19	(00011001)
Single Data Frame,	DAT	=	0x1A	(00011010)
End of Frame,	EOF	=	0x1F	(00011111)
Write Password 1,	WP1	=	0xE5	(11100101)
Write Password 2,	WP2	=	0xA2	(10100010)



11.3. Frame Structure

The start of a frame is indicated by a DLE byte followed by the type of frame to follow (RD, WR, ACK, NAK, DAT). The end of frame is indicated by a DLE byte followed by an EOF byte.

Note: Each of the constants has bit 4 set and so is slip-resistant (i.e. if shifted this bit will be out of position). The values have a Hamming Distance of 2 (each code is at least 2 bits different from every other code).

Any DLE bytes that occur between a frame's start and end are prefixed with another DLE (*byte-stuffing*).

Following the EOF is a 16-bit checksum of the entire frame, each byte is added to produce the checksum.

11.4. Variables

Each piece of accessible data on a device is referred to as a *Variable*. Each variable is referenced by a *Variable ID*. A variable ID may be any number of bytes long.

The available Variables and their corresponding Variable IDs depend on the type of device, but here are a few examples for the FGD10A:-

General Configuration	0x00
Live Data	0x01
Zero Sensor	0x02
Span Sensor	0x03
Version Information	0x04
Firmware Update	0x05

The structure of the data returned in each variable usually depends both on the type of device and the version of firmware running on the device. Refer to device documentation for more information.



11.5. Reading a Variable

Send a read frame with the Variable ID to be read:

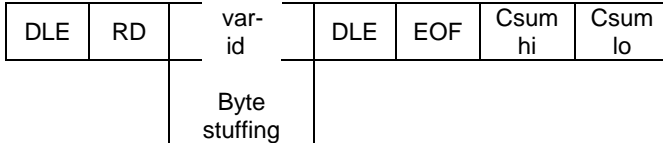

Device response on success, where requested variable data < 255 bytes:



Device response on failure:

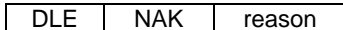

Where 'reason' is a single byte failure code, the meaning of which depends on the device type, i.e.

- Reason = 1, NotReadable,
- Reason = 2, ReadOutOfRange

STATUS SCIENTIFIC CONTROLS

Installation, Commissioning & Routine Gas Testing
FGD10A Flammable (Pellistor) Gas Detector



11.5.1. Read example - read live data

The following example is based on V4.x.xE where the data is either byte or integer types only.

Send the following bytes:

DLE, RD, Variable ID, DLE, EOF, Checksum High byte, Checksum low byte i.e.

0x10, 0x13, 0x01, 0x10, 0x1F, 0x00, 0x53

Device response on success:

DLE, DAT, Data length, Data, DLE, EOF, Checksum High byte, Checksum low byte, i.e.

0x10	DLE
0x1A	DAT
0x0D	Data length
0x03	Version
0x01	Display mode
0x07	Sensor Type
0x00, 0x00	Gas reading (signed integer x 100) = 0
0xAE, 0x0B	Current sensor temperature (signed integer x 100) = 29.9
0x92, 0x08	Active sensor signal (unsigned integer) = 2194
0xD7, 0x04	Reference sensor signal (unsigned integer) = 1239
0x10	DLE
0x1F	EOF
0x02	Checksum high byte
0x9F	Checksum low byte

STATUS SCIENTIFIC CONTROLS

Installation, Commissioning & Routine Gas Testing
FGD10A Flammable (Pellistor) Gas Detector



11.6. Writing a Variable

Send a write frame with the Variable ID to be written:

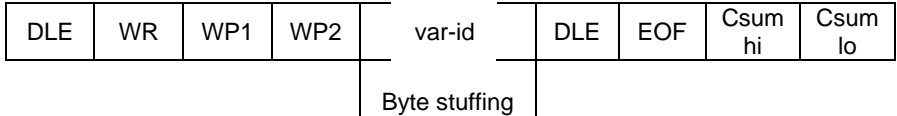

Device response on success:

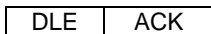

Where data to write is < 255 bytes, send a DAT frame:



Device response on write success:



Device response on write failure:



Where 'reason' is a single byte failure code, the meaning of which depends on the device type, i.e.

- Reason = 1, NotWritable
- Reason = 2, WriteOutOfRange
- Reason = 3, BadDataLength
- Reason = 4, IncorrectVersion



12. ROUTINE GAS TESTING

Refer to Figure 6 in section 7. showing the arrangement for applying the test gas to the FGD10A.

1. Before application of the test gas, check that the FGD10A reads zero with no known gas present in the atmosphere. If necessary, carry out adjustment of the zero setting as described in section 9.1.1.
2. Apply the test gas and allow a sufficient time for the sample to reach the gas detector. The response time will vary according to the length of the sampling tube.
3. **Record the time taken** for the gas detector to provide a reading of 90% (T_{90}) of its final value (e.g. to reach 18.8% when using a 20.9% O_2 test gas after exposure to nitrogen). This reading should be retained for future reference as it can provide an indication of the health of the sinter (flame arrestor). This is situated in the base of sensor housing and it is through this device that the gas passes in order to reach the sensor itself. If necessary, carry out adjustment of the span setting as described in section 9.1.2.

Carrying out the above procedure, and comparing the results with previous readings, will confirm that the FGD10A is functioning correctly, both physically and electrically. There is therefore no requirement for any further maintenance other than to clean the display window as required.

In the unlikely event that the response time is seen to be increasing, when comparing periodic readings, it is advisable to change the unit so that it can be checked.

The period between carrying out routine gas testing shall be in accordance with the customer's specification.

STATUS SCIENTIFIC CONTROLS

Installation, Commissioning & Routine Gas Testing

FGD10A Flammable (Pellistor) Gas Detector



13. SENSOR REPLACEMENT

13.1. Flammable (Pellistor) sensor

To order a replacement 'pellistor' sensor, quote Stock No. SS294.

Step 1

Turn cover securing stud anti-clockwise to allow cover to open.

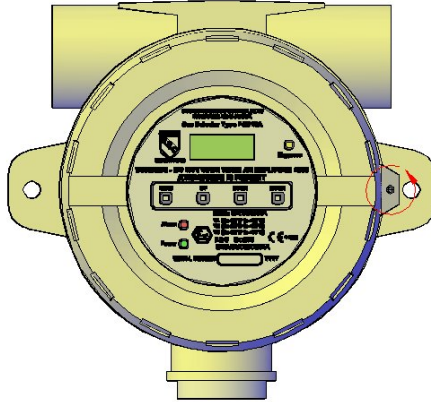

Step 2

Remove cover by rotating anti-clockwise

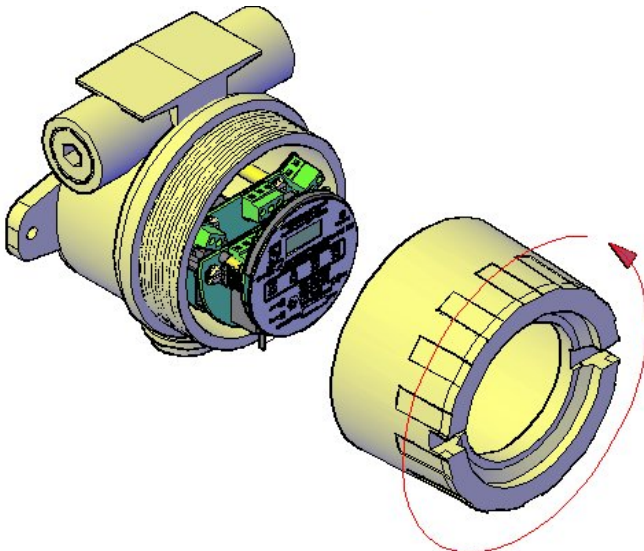

STATUS SCIENTIFIC CONTROLS

Installation, Commissioning & Routine Gas Testing
FGD10A Flammable (Pellistor) Gas Detector



Step 3

Remove the display board - which can be left to dangle on its retaining wire.
Remove the PCBs from the support pillars and the ribbon cable from the board remaining in the enclosure.

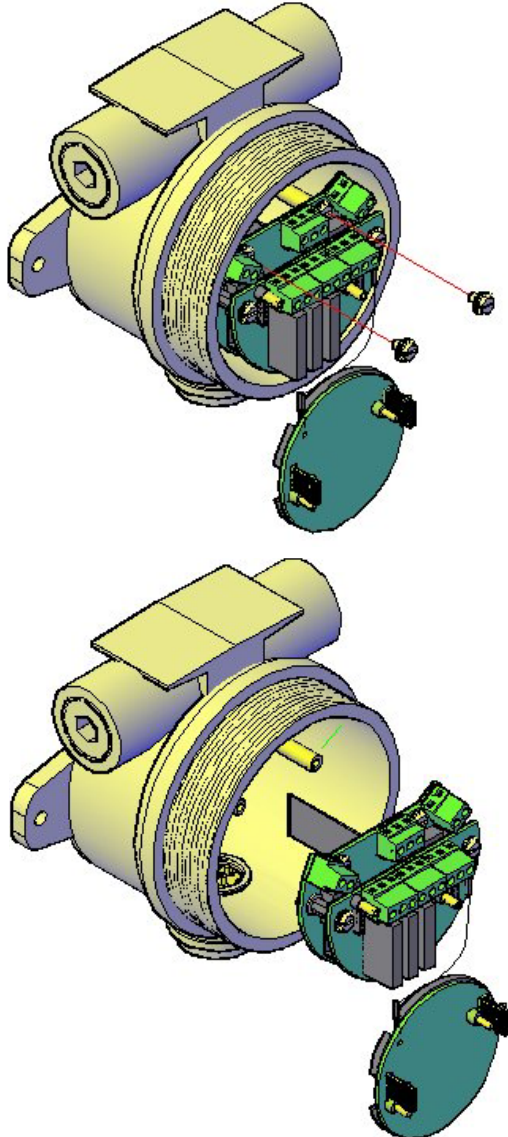

STATUS SCIENTIFIC CONTROLS

Installation, Commissioning & Routine Gas Testing
FGD10A Flammable (Pellistor) Gas Detector



Step 4

Remove the flammable (pellistor) sensor board from the rear of the sensor – do not disconnect the wires from the main board.

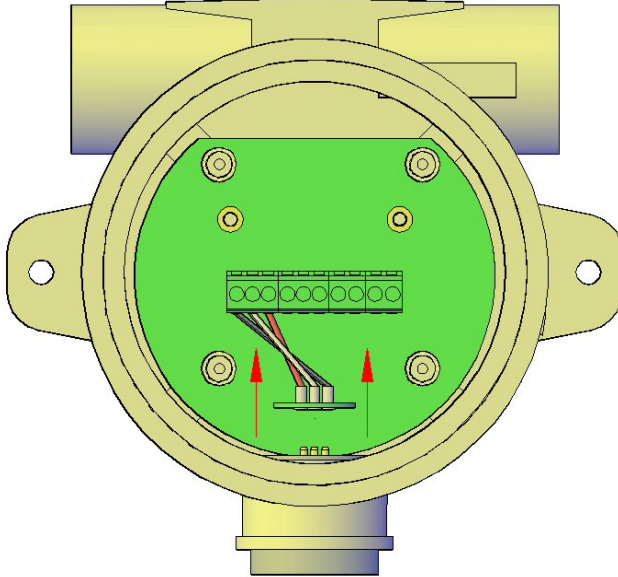

STATUS SCIENTIFIC CONTROLS

Installation, Commissioning & Routine Gas Testing
FGD10A Flammable (Pellistor) Gas Detector



Step 5

Remove sensor insert using extraction tool

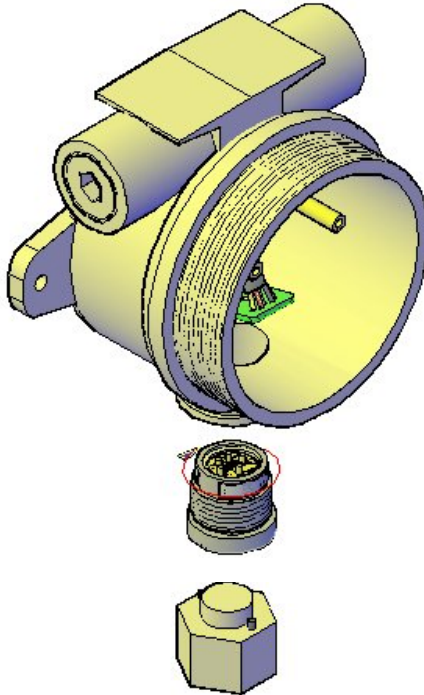

STATUS SCIENTIFIC CONTROLS

Installation, Commissioning & Routine Gas Testing
FGD10A Flammable (Pellistor) Gas Detector



Step 6

Mark the sensor pin position & undo the circlip that retains the sensor in its housing.

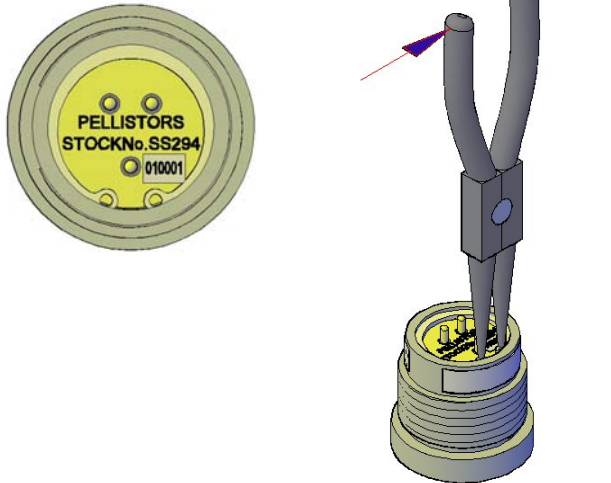

Step 7

Replace the sensor taking note of the pin marking in step 6.

STATUS SCIENTIFIC CONTROLS

Installation, Commissioning & Routine Gas Testing
FGD10A Flammable (Pellistor) Gas Detector



Step 8

Apply Loctite 243 or a compound equal strength to the threads. Insert the sensor housing into the FGD10A enclosure using the insertion tool.

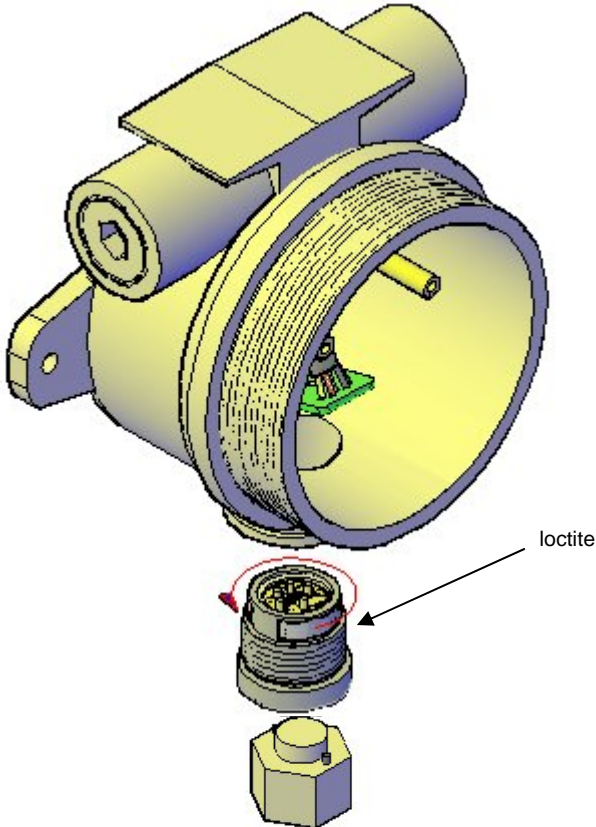

STATUS SCIENTIFIC CONTROLS

Installation, Commissioning & Routine Gas Testing

FGD10A Flammable (Pellistor) Gas Detector



Step 9

Fix the pellistor sensor board back into position.

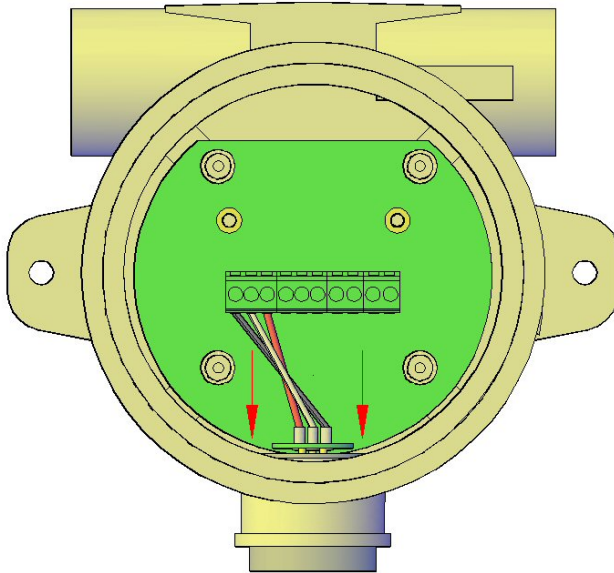

STATUS SCIENTIFIC CONTROLS

Installation, Commissioning & Routine Gas Testing
FGD10A Flammable (Pellistor) Gas Detector



Step 10

Fix ribbon cable, the boards removed from the support pillars and finally the display board back into position.

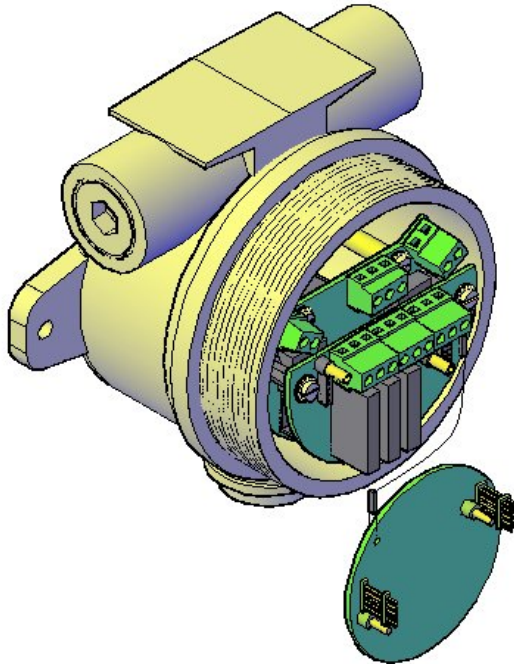

STATUS SCIENTIFIC CONTROLS

Installation, Commissioning & Routine Gas Testing
FGD10A Flammable (Pellistor) Gas Detector



Step 10

Replace cover and fully tighten.

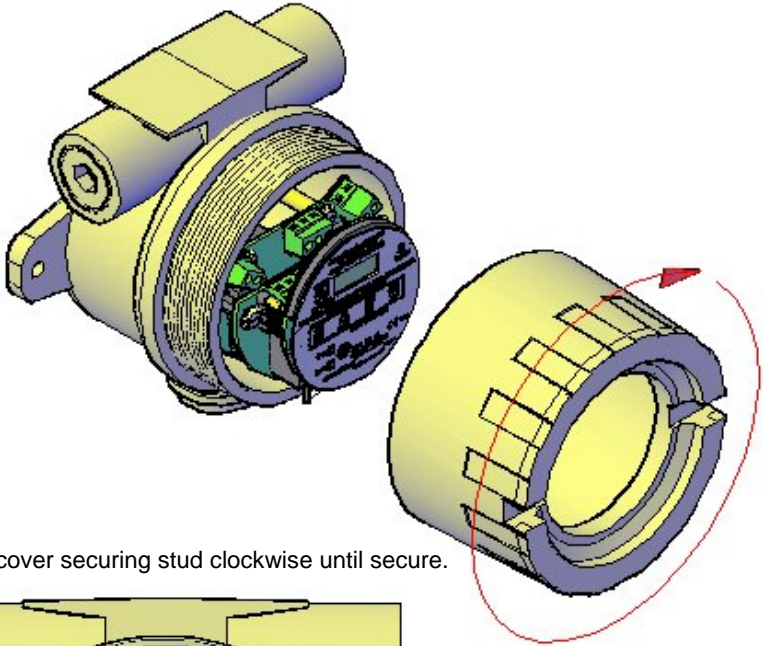

Step 11

Turn the cover securing stud clockwise until secure.

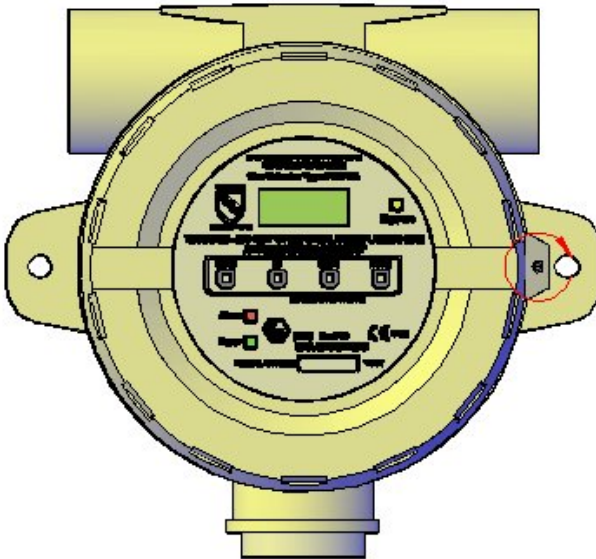



14. FUSES

A 1Amp anti-surge fuse, housed within a surface mounted holder, is located within the FGD10A to prevent overloading of the electronic circuitry in the event of an internal fault.

In the event of the internal fuse blowing, access can be gained using the following procedure:

1. Switch OFF the supply to the FGD10A.
2. Release the grub screw located near the lip of the enclosure cover.

Note:

It is not necessary to remove the grub screw to release the enclosure front cover.

3. Remove the enclosure front cover by rotating it several times in an anti-clockwise direction.
4. Unplug the display board from within the enclosure.
5. Remove the 3 screws located around the edge of the next board.
6. Unplug this board.
7. The surface mounted fuse holder can now be located on the board below. Replace only with a fuse of the same type and rating:-

1Amp Antisurge 'Nanofuse' (SSCL Code: 160153)

Assembly is the reverse of the above procedure.

STATUS SCIENTIFIC CONTROLS

Installation, Commissioning & Routine Gas Testing
FGD10A Flammable (Pellistor) Gas Detector



15. SPECIFICATION

Materials	: Instrument Body – Aluminium Pressure Die Casting : Sensor Insert – Stainless Steel Grade 316 : Magnetic Pen – Stainless Steel Grade 316 : Weather guard – Stainless Steel Grade 304 & Nylon 66
Cable entries	: 2 x 20mm
Weights	: FGD10A (excluding weather guard) – 1.5Kg : Magnetic Pen – 60 grams : Weather guard – 200 grams
Gas type	: Flammable gases including Methane and Hydrogen
Input voltage	: 8 to 24 volts dc
Input power	: 5 Watts maximum
Internal fuse	: 1 Amp antisurge 'Nanofuse'
Analogue output	: 4 to 20mA (10 bit resolution)
Relays	: Relay 1 – Alarm 1 : Relay 2 – Alarm 2 : Relay 3 – Fault : Contact Rating 300Vac, 3 Amps (Non-inductive load)
RS232 output	: Communications with PC at 19200 baud
Sensor type	: Pellistor, 2.5v dc, 170mA
Measurement range	: 0 – 100% LEL
Response time	: < 10 seconds
Measurement resolution	: 1% LEL
IP rating	: Enclosure IP66, Sensor IP65
Display	: 4 Digit, 7 segment liquid crystal
Keypad	: 4-Button magnetically operated
Software	: Software configuration provided via LCD display and multifunction keypad
Operating temperature	: - 20 to +60 °C
Humidity range	: 0 to 95% RH non-condensing
Operating pressure	: Atmospheric + or - 10%
Performance standards	: EN 60079-29-1:2007

16. DIMENSIONS

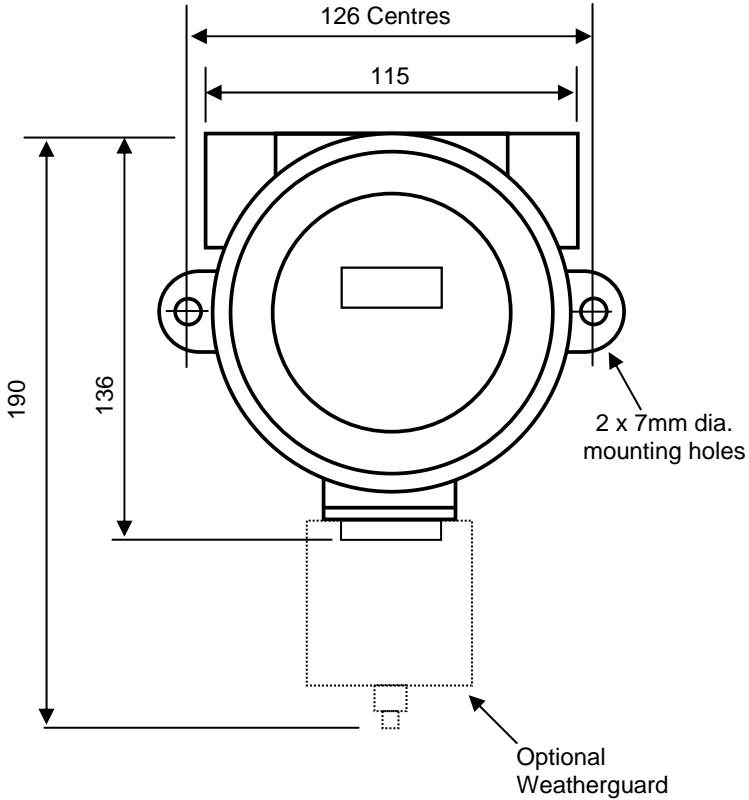

Maximum Depth = 127mm

17. CERTIFICATION

The FGD10 Series of Gas Detectors are ATEX and IECEx certified for use in potentially explosive atmospheres and is marked as follows:-

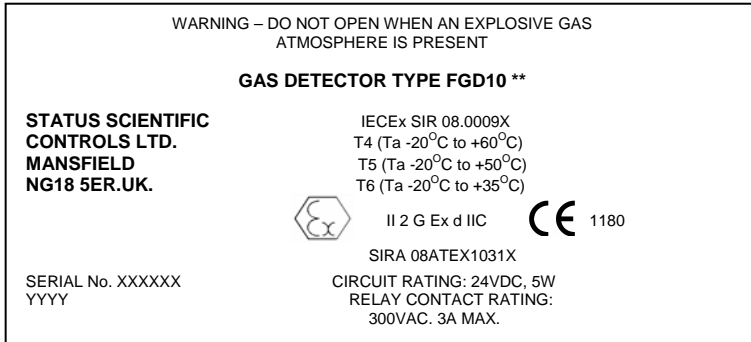

** Denotes additional characters that define the gas detector configuration e.g. Enclosure type and sensor arrangement.

YYYY – Denotes year of manufacture.

Special Conditions of Safe Use

1. The gap between the SI-IR sensor and its housing in the gas detector is 0.11mm maximum and should not be enlarged during maintenance etc.
2. Only Loctite 243 or a compound equal strength shall be re-applied to the threads of the type SI-M sensor after replacing the sensing element.
3. The SI-IR sensors shall not be installed or removed when an explosive gas atmosphere is present.

Note: Conditions 1 and 3 are not applicable to this product.

STATUS SCIENTIFIC CONTROLS

Installation, Commissioning & Routine Gas Testing
FGD10A Flammable (Pellistor) Gas Detector



Compliance with the Essential Health and Safety Requirements has been assured by compliance with:

EN 60079-0: 2006

EN 60079-1 : 2007

Electrical data

Power supply - 8Vdc to 24Vdc, 5W
Relay contact rating – 300Vac, 3 Amps

Installation instructions

The cable entry devices and blanking elements of unused apertures shall be of a certified flameproof type, suitable for the conditions of use and correctly installed.

With the use of conduit, a suitable certified sealing device such as a stopping box with compound shall be provided immediately at the entrance to the flameproof enclosure.

A copy of the certificate is available for download from:-

www.status-scientific.com

STATUS SCIENTIFIC CONTROLS

Installation, Commissioning & Routine Gas Testing

FGD10A Flammable (Pellistor) Gas Detector



CUSTOMER NOTES