

STATUS SCIENTIFIC CONTROLS

Issue: 3.6
Date: 18/02/10
Version: 9.1At



FGD3 Atex Oxygen and Toxic Detector Heads

STATUS SCIENTIFIC CONTROLS LTD.
Hermitage Lane Industrial Estate,
Kings Mill Way,
Mansfield,
Nottinghamshire.
NG18 5ER
England
Tel : 01623 651381
Fax : 01623 421063

STATUS SCIENTIFIC CONTROLS

Status Scientific Controls Ltd
Hermitage Lane Industrial Estate,
Kings Mill Way, Mansfield,
Nottinghamshire, England.
NG18 5ER
www.status-scientific.com



Manufacturer's EC Declaration of Conformity

We declare, under our sole responsibility, that we believe the products identified in this declaration, and to which this declaration relates are in conformity with the requirements of the following Council Directives:

- 89/336/EEC as amended by 92/31/EEC on the approximation of the laws of the Member States relating to Electromagnetic Compatibility.
- 94/9/EC on the approximation of the laws of the Member States concerning equipment and protective systems intended for use in potentially explosive atmospheres.

Description of Equipment: The FGD1-3 Series of Fixed Gas Detectors for the detection of Oxygen, Toxic or Flammable gases. ATEX Certified intrinsically safe for use in Group IIC hazardous locations.	
Standards applied: Electrical apparatus for potentially explosive atmospheres -General requirements. EN50014:1997 + Amds 1 & 2 Electrical apparatus for potentially explosive atmospheres -Intrinsic safety 'I'. EN50020:1994 Electrical apparatus for potentially explosive atmospheres -Flameproof enclosure 'd'. EN50018:2000 Electromagnetic compatibility - Electrical apparatus for the detection and measurement of combustible gases, toxic gases or oxygen. EN50270:1999 Electromagnetic compatibility. Generic emission standard. Industrial environment. EN61000-6-4:2001 Electromagnetic compatibility. Generic standards. Immunity standard for industrial environments. EN61000-6-2:1999	
Notified Body for Hazardous Area Certification: Baseefa Rockhead Business Park Staden Lane, Buxton SK17 9RZ, UK Notified Body Number : 1180	Notified Body for ATEX Quality Assurance Notification: Baseefa Rockhead Business Park Staden Lane, Buxton SK17 9RZ, UK Notified Body Number : 1180
Product Hazardous Area Certificate Number: BAS 01ATEX2300	ATEX Quality Assurance Notification Number: 2056
Place of Manufacture: Mansfield, Nottinghamshire, UK. <small>Date mark applied -see product</small>	ISO 9001:2000 Quality Management System: Certificate No. GB93/1938

Authorised Signatory to this declaration, on behalf of the manufacturer:

Name: W. R. Baxter Title: Managing Director
Address: Status Scientific Controls Ltd, Hermitage Lane Industrial Estate, Kings Mill Way
Mansfield, Nottinghamshire, NG18 5ER, United Kingdom
Signature:  Date: 1.8.06

Tel : +44 (0)1623 651381
Fax : +44 (0)1623 421063 and 427816
e-mail : sales@status-scientific.com

STATUS SCIENTIFIC CONTROLS

FGD O₂ and Toxic Detector Heads

STATUS SCIENTIFIC CONTROLS



Issue: 3.6

Date: 18/02/10

Version: 9.1At

7 MOUNTING DETAILS

The diagram below shows the mounting centres for the FGD Detector Head Enclosure.

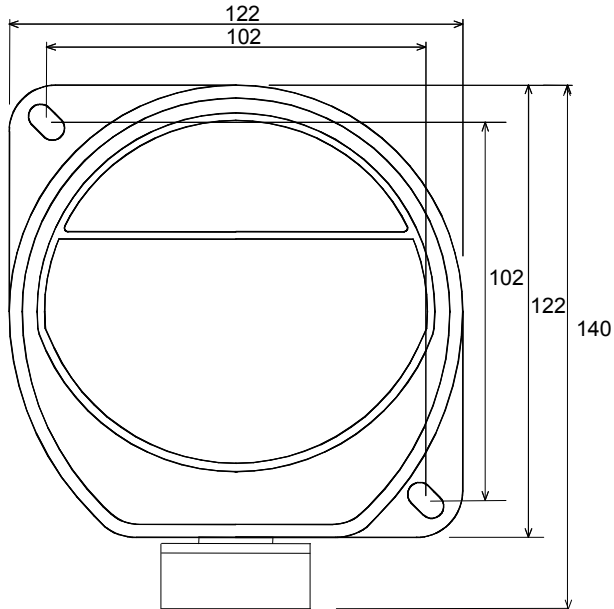

Depth = 75mm approx

Note:

The front panel/lid of the detector head opens to allow access to the screw terminals situated inside. Sufficient space should be allowed around the mounting position so that this action is not restricted.

Fixings Required:

2 off M6 Fasteners

(Rawl Bolts or similar dependent on mounting wall construction)



FGD3 Atex Gas Detector Head with Plug-In Sensor



FGD3 Atex Gas Detector Head with Internal Sensor

STATUS SCIENTIFIC CONTROLS

FGD O₂ and Toxic Detector Heads

STATUS SCIENTIFIC CONTROLS

FGD O₂ and Toxic Detector Heads

1	INTRODUCTION.....	1-1
1.1	INSTALLATION	1-1
1.1.1	<i>Siting the Sensors.....</i>	1-1
1.1.2	<i>Wire Termination</i>	1-2
1.1.3	<i>Cable Routing.....</i>	1-2
1.1.4	<i>Cable & Screening.....</i>	1-2
2	INSTALLATION IN A NON-HAZARDOUS LOCATION.....	2-1
2.1	INSTALLATION IN A HAZARDOUS LOCATION.....	2-2
3	MENU MODE SELECTION	3-1
3.1	ZERO SENSOR	3-2
3.2	SENSOR SPAN	3-3
3.3	SELECT FSD	3-3
3.4	SETTING 4MA LEVEL	3-4
3.5	SETTING 20MA LEVEL.....	3-4
3.6	DISPLAY MODE	3-5
3.7	DISPLAY FIRMWARE VERSION	3-5
3.8	RESTORE	3-6
3.9	VIEW ENGINEER/DIAGNOSTICS DATA.....	3-7
3.10	SET CROSS REFERENCE	3-7
3.11	POSITIVE ZERO SUPPRESSION.....	3-8
3.12	NEGATIVE ZERO SUPPRESSION	3-8
3.13	PASSWORD.....	3-9
4	FGD3 HEAD INDICATIONS	4-1
4.1	NORMAL CONDITIONS	4-1
4.2	HIGH GAS CONDITIONS	4-1
4.3	FAULT CONDITIONS	4-1
5	SENSOR REPLACEMENT.....	5-1
6	CERTIFICATION	6-1
7	MOUNTING DETAILS	7-1

6 CERTIFICATION

The FGD Oxygen and Toxic gas detectors carry the following markings:

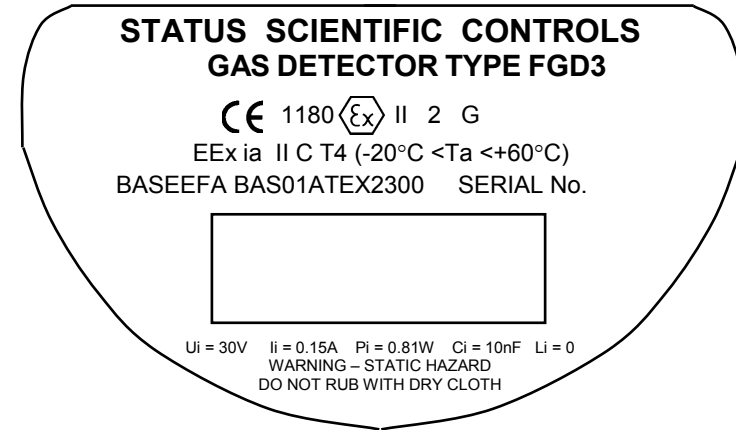

STATUS SCIENTIFIC CONTROLS

FGD O₂ and Toxic Detector Heads

STATUS SCIENTIFIC CONTROLS

FGD O₂ and Toxic Detector Heads

Arrangement (B)

- a) Inhibit the channel at the control unit.
- b) Disconnect power to the head at the control unit.
- c) Release sensor housing by undoing the locking ring or splashguard adaptor depending upon which is fitted.
- d) Unscrew the two M4 screws of the terminal box chassis and remove.
- e) Remove the sensor housing from the detector.
- f) Unscrew the four countersunk screws from the sensor housing cover plate to reveal the sensor.
- g) Remove the sensor and replace with the new sensor, taking note of the wire positions and colour codes.
- h) Replace the cover plate and tighten the four screws.
- i) Replace the sensor housing locking ring or splashguard adaptor.
- j) Refit the terminal box chassis to the instrument.
- k) Allow the sensor to stabilise for 1-2 hours prior to calibration.
- l) Calibrate the detector head.
- m) Enable the channel at the control unit.

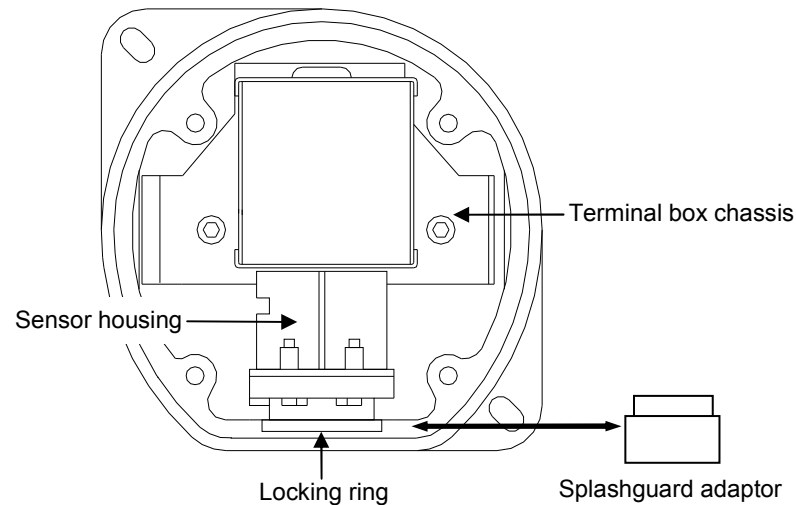

1 INTRODUCTION

Status Scientific Controls FGD3 O₂ and Toxic Detector Heads are 4-20mA loop powered gas detectors designed to monitor gas levels in the atmosphere. The sensor type fitted within the head dictates the gas type to be monitored, and the range to which the head is sensitive.

The detectors use the industry standard 4-20mA current loop to convey the gas levels to a control unit. This means that under *zero gas* conditions 4mA is drawn from the supply, and under *full scale* gas conditions 20mA is drawn from the supply. The current varies linearly for gas levels between zero and full scale.

1.1 Installation

1.1.1 Siting the Sensors

Mounting positions for sensors need to be considered individually, some points for consideration are:

- Ensure all sensors are mounted to allow routine calibration and maintenance to be carried out as required.
- Ensure the proposed site will not interfere with movement of existing equipment, e.g. cranes, doors etc
- Install all cables neatly and securely.
- Sensors for detecting gases that are lighter than air should be positioned at a high level.
- Sensors for heavier than air gases should be located at below head height.
- Avoid siting the sensors adjacent to potential sources of radio frequency interference, e.g. radio transmitters, control switchgear, motors etc.

STATUS SCIENTIFIC CONTROLS

FGD O₂ and Toxic Detector Heads

STATUS SCIENTIFIC CONTROLS

FGD O₂ and Toxic Detector Heads

1.1.2 Wire Termination

All connections should be made according to the appropriate sensor or loop diagram for the configuration required. It is advised that 'Bootlace Ferrules' or 'flat blade crimps' be used for tidy and reliable connections of wires into the Detector Head connectors.

1.1.3 Cable Routing

Due to the low signal levels generated by gas detectors it is recommended that all wiring to the sensors be segregated away from AC mains or other high voltage/power lines to avoid interference.

1.1.4 Cable & Screening

The use of a screened cable is recommended for the installation of all detector heads. The correct strategy for connecting the screens depends upon the area in which the detector head is to be used (i.e. hazardous/ non-hazardous). In all cases the screen should not be connected at the detector head. Refer to the connection diagrams on the following pages for further information.

The Oxygen and Toxic detector heads require a two wire connection to the control unit:

- + current loop to head
- current loop return to control unit

5 SENSOR REPLACEMENT

Note: Applies only to instruments fitted with an integral sensor.

Arrangement (A)

- a) Inhibit the channel at the control unit.
- b) Disconnect power to the head at the control unit.
- c) Release the sensor retainer.
- d) Unplug the sensor from the PCB.
- e) Push the new sensor into the PCB, making sure of the pin alignment.
- f) Refit the sensor retainer.
- g) Allow the sensor to stabilise for 1-2 hours prior to calibration.
- h) Calibrate the detector head.
- i) Enable the channel at the control unit.

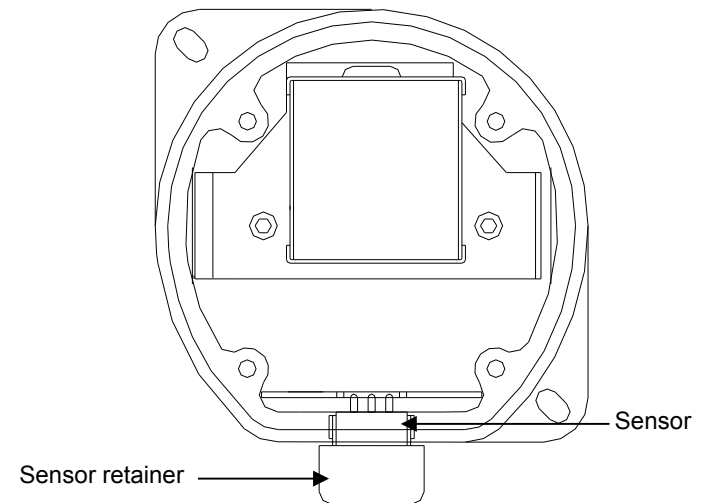

STATUS SCIENTIFIC CONTROLS

FGD O₂ and Toxic Detector Heads

STATUS SCIENTIFIC CONTROLS

FGD O₂ and Toxic Detector Heads

4 FGD3 HEAD INDICATIONS

4.1 Normal conditions

The FGD3 gas Detector Head will display a steady reading for gas levels between 0 and FSD.

4.2 High gas conditions

The FGD3 gas Detector Head will flash between the gas reading and 'Hi ' when the gas reading is above the sensor FSD. This will coincide with the head drawing a current of 20 - 25mA from the control unit, thus ensuring the control unit is aware of the high condition.

4.3 Fault conditions

The FGD3 gas Detector Head will flash between 'F xx' and the gas reading when the reading falls below -10% of the sensor FSD. This will coincide with the head drawing a current of less than 2.5mA from the control unit, thus ensuring the control unit is aware of the fault condition.

Note: xx is a number that defines a particular fault as follows:

- 1 Checksum error.
- 2 Zero calibration error.
- 4 Span calibration error.
- 8 Sensor reference low output.
- 16 Sensor reference high output.
- 32 Sensor detector low output.
- 64 Sensor detector high output.

Note: multiple faults may be shown i.e. F:6 indicates that there is a zero and span calibration error.

2 INSTALLATION IN A NON-HAZARDOUS LOCATION.

When a detector head is installed in an area where there is no potential of an explosive gas hazard present, the cable lengths to the detector are limited solely by the resistance of the cable. The FGD3 gas detectors require a minimum of 8V between the Sig and 0V terminals to allow them to operate correctly.

For systems operating at 24V, the maximum cable loop resistance is therefore (24-8)/25mA i.e. 640Ω.

The diagram above shows connections for FGD1/2 Detector Head in a non-hazardous location. The pin numbers shown at the control unit refer to pin numbers on the Status Scientific Input Modules within the MCU Control Units. Refer to manufacturer if alternative control unit is used.

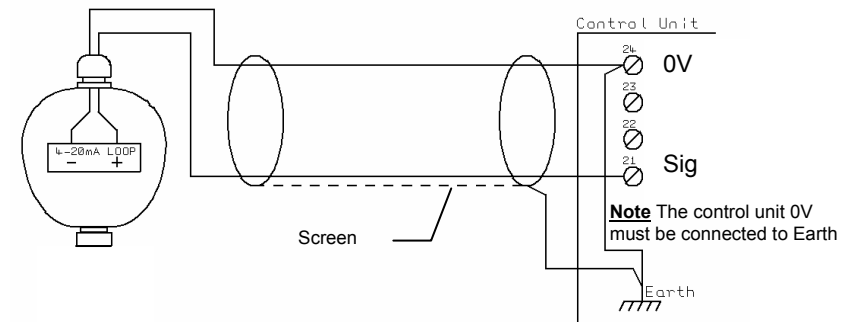

STATUS SCIENTIFIC CONTROLS

FGD O₂ and Toxic Detector Heads

2.1 Installation in a hazardous location.

When used in a hazardous area, the FGD3 detector requires an intrinsically safe (I.S.) power supply. This can be provided by using proprietary safety barriers¹.

The use of barriers to create an I.S. supply imposes certain restrictions on the parameters of the interconnecting cables used. Consult the barrier manufacturers data for further information.

Barriers must be selected to restrict the I.S. supply to the gas detectors within the following parameters:

Gas Detector	Terminals	U _{max}	I _{max}	P _{in}	Ci	Li
FGD3 Oxygen or Toxic	- and +	30V	0.15A	0.81W	10nF	0

When considering the capacitance and inductance allowable across the barrier output terminals, there is 10nF capacitance and zero inductance between terminals '-' and '+' on any model of FGD detector.

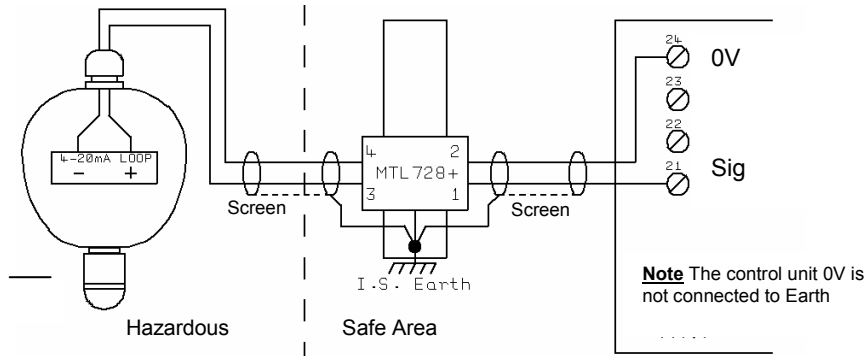

¹ If a Status Scientific MCU Control Unit is being used, then the Status I.S. Output Module type FGDI0 can be used to provide the necessary I.S. outputs. This module is located within the MCU enclosure. Refer to FGD System Installation and Operation Manual for details.

STATUS SCIENTIFIC CONTROLS

FGD O₂ and Toxic Detector Heads

3.13 Password

This option is used to allow the user to limit the option available for users by means of a password.

- Press MENU to open the menu system.
- Using the NEXT and PREVIOUS buttons, select menu option: **E:30**
- Press ENTER.
- Using the up button, toggle the display between OFF & On.
- Press ENTER to store the new value.
Note: Pressing the MENU button rather than the ENTER button exits without any change.
- Press MENU to close the menu system.

Note: if the password should be obtained from Status Scientific Controls before selecting the 'On' setting.

The password limits the user to menu options 1,2,4 and 5.

STATUS SCIENTIFIC CONTROLS

FGD O₂ and Toxic Detector Heads

STATUS SCIENTIFIC CONTROLS

FGD O₂ and Toxic Detector Heads

3.11 Positive Zero Suppression

This option is used to allow the user to suppress small amounts of positive sensor zero drift. The setting can be set between 0 and 10% of the sensor range as set by the FSD value.

- Press MENU to open the menu system.
- Using the NEXT and PREVIOUS buttons, select menu option: **E:19**
- Press ENTER.
- Using the INCREASE and DECREASE buttons, set the required zero suppression value.
- Press ENTER to store the new value.
Note: Pressing the MENU button rather than the ENTER button exits without any change.
- Press MENU to close the menu system.

3.12 Negative Zero Suppression

This option is used to allow the user to suppress small amounts of negative sensor zero drift. The setting can be set between 0 and 10% of the sensor range as set by the FSD value.

- Press MENU to open the menu system.
- Using the NEXT and PREVIOUS buttons, select menu option: **E:20**
- Press ENTER.
- Using the INCREASE and DECREASE buttons, set the required zero suppression value.
- Press ENTER to store the new value.
Note: Pressing the MENU button rather than the ENTER button exits without any change.
- Press MENU to close the menu system.

3 MENU MODE SELECTION

In order to gain access to the menu switches and test points, release the screw situated between the letters A and T of the chrome STATUS label on the Detector Head front panel. The screw does not need to be completely removed, only release it far enough so that the STATUS label can rotate revealing the calibration switches and test points. The buttons and test points are designated as follows:

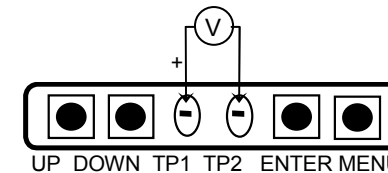

Several calibration modes exist in the detector head and these are accessible via the instruments simple menu system. To select a menu mode follow this procedure:

- Press the MENU button and **C: 1** appears on the display.
- Press UP or DOWN until the required menu mode is displayed on the screen.
- Press ENTER to select the menu mode.
- To exit the menu mode press MENU.

While the instrument is in a menu mode – any data displayed on the screen will alternate between the menu number and the reading.

If the password is set the user will be prompted with PASS when the MENU key is pressed. The user has the option of ignoring the password by simply pressing the MENU key, in this case a limited menu system is offered or entering the correct password to gain access to the full menu options.

STATUS SCIENTIFIC CONTROLS

FGD O₂ and Toxic Detector Heads

STATUS SCIENTIFIC CONTROLS

FGD O₂ and Toxic Detector Heads

The 'FGD3' menu system is as follows: -

Cal number	Function	Section
1	Zero Sensor	3.1
2	Sensor Span	3.2
3	Select FSD	3.3
4	Setting 4mA Level	3.4
5	Setting 20mA Level	3.5
6	Display mode	3.6
7	Display Firmware Version	3.7
8	Restore	3.8
9	View Engineer/Diagnostics Data	3.9
12	Set Cross reference	3.10
19	Positive zero suppression	3.11
20	Negative zero suppression	3.12
30	Password	3.13

3.1 Zero Sensor

This calibration feature allows the instrument to determine the sensor output under zero gas conditions.

- Apply zero gas to the sensor inlet and allow enough time for the sensor to respond and all the gas to be purged (typically 2 minutes minimum dependent upon flow rate).
- Select menu mode **C: 1** and press ENTER.
- Press ENTER to perform the ZERO calibration. Pressing MENU instead of ENTER aborts the calibration (the ZERO factor will still be displayed on exit).
- Press MENU – the display will show the ZERO factor for the instrument before returning to its standard mode of operation.

The ZERO factor should be recorded on any calibration certificates.

3.9 View Engineer/Diagnostics Data

This feature is a *view-only* feature. No configuration changes are possible from within this menu.

This information is for the use of Status Scientific Controls.

- Select menu mode **C: 9** (refer to section 3) and press ENTER.
- The display will alternate between the current value and code **C: 9x**: where x is:
 - 0 Sensor reading.
 - 4 Detector AtoD counts.
- The mode of operation can be selected by pressing the UP button.
- Press MENU to return the instrument to its standard mode of operation.

Note1: the diagnostic structure is compatible with other gas types and as such certain features are not available, N/A.

Note2: the diagnostic option 95 is only of use where a four electrode electro-chemical sensor is fitted.

3.10 Set Cross reference

Menu mode **C: 12**

This option is used to allow the user to calibrate the sensor with a commonly available gas (e.g. methane or propane) but use the unit to detect a different gas (e.g. methanol or acetone etc.). This is achieved by adjusting the cross-reference factor according to the difference in signal that is detected for the calibration gas compared to the target gas.

- Press button 1 to open the menu system.
- Select menu mode **C:12** (refer to section 3) and press ENTER.
- Press ENTER.
- Using the INCREASE and DECREASE buttons (buttons 3 & 4), set the required cross-reference factor.
- Press ENTER to store the new value.
- Press button 1 to close the menu system.

Ask Status Scientific Controls for advice on settings.

STATUS SCIENTIFIC CONTROLS

FGD O₂ and Toxic Detector Heads

STATUS SCIENTIFIC CONTROLS

FGD O₂ and Toxic Detector Heads

3.8 Restore

The firmware for the detector head is common to infrared CO₂, HC, Pellistor, Oxygen and Toxic instruments. This feature allows the type of sensor fitted to be selected.

IMPORTANT

The instrument supplied with this manual has either an oxygen or toxic sensor installed.

Changing the setting within this menu will not change the gas to which the sensor responds.

- Select menu mode **C: 8** (refer to section 3) and press ENTER.
- Use the UP button to toggle the sensor type (see table below)
- Press ENTER. Pressing MENU instead of ENTER aborts the feature.
- Press MENU to return the instrument to its standard mode of operation.

Sensor type	Range	display
O2-1	0-25%vol non-linear	0.0 - 20.9
O2-2	0-25%vol linear	0.0 - 20.9
Elt1	5 ppm	0.0 – 5.0
Elt2	10 ppm	0.0 – 10.0
Elt3	20 ppm	0.0 – 20.0
Elt4	50 ppm	0.0 – 50.0
Elt5	200 ppm	0 – 200
Elt6	500 ppm	0 – 500
Elt7	1000 ppm	0 – 1000
Elt8	9999 ppm	0 - 9999

This feature will erase all the configuration settings of the detector head and replace them with the instruments default values for the sensor selected. Following the use of this feature the instrument must have a full calibration (including the 4-20mA loop).

Note: a linearization algorithm is applied to the O2-1 sensor type as supplied by City Technology.

3.2 Sensor Span

This calibration feature allows the instrument to determine the sensor output when it is exposed to a know concentration of gas.

- Apply a known concentration of gas to the sensor inlet and allow enough time for the sensor to respond.
- Select menu mode **C: 2** (refer to section 3) and press ENTER.
- Using the UP and DOWN buttons, adjust the displayed reading so that it matches the calibration gas concentration.
- Press ENTER to perform the SPAN calibration. Pressing MENU instead of ENTER aborts the calibration (the SPAN factor will still be displayed on exit).
- Press MENU – the display will show the SPAN factor for the instrument before returning to its standard mode of operation.

The SPAN factor should be recorded on any calibration certificates.

3.3 Select FSD

The FSD value is usually matched to the sensor fitted. If the sensor is say a 0-20 ppm chlorine sensor then the FSD is set to 20. It is possible to transmit a lower range on the 4 to 20 mA signal by reducing this value to say 10 ppm.

This function does not affect the sensor calibration but does change the maximum reading that can be measured.

Note: Changing this value outside the sensor's operating range may make the FGD3 unsuitable for its intended use.

- Select menu mode **C: 3** (refer to section 3) and press ENTER.
- Using the UP and DOWN buttons, adjust the displayed reading until the desired setting is displayed.
- Press ENTER to save the setting. Pressing MENU instead of ENTER aborts the calibration (the sensor FSD factor will still be displayed on exit).
- Press MENU – the display will show the sensor FSD for the instrument before returning to its standard mode of operation.

STATUS SCIENTIFIC CONTROLS

FGD O₂ and Toxic Detector Heads

STATUS SCIENTIFIC CONTROLS

FGD O₂ and Toxic Detector Heads

3.4 Setting 4mA Level

This calibration feature allows the instrument to simulate a condition of zero gas so that the 4mA output can be set.

- Attach a multimeter (set to measure DC voltage) between test points TP1 and TP2.
- Select menu mode **C: 4** (refer to section 3) and press ENTER.
- Using the UP and DOWN buttons, adjust the reading displayed on the multimeter to 40mV \pm 0.5mV
- Press ENTER to store the 4mA calibration data. Pressing MENU instead of ENTER aborts the feature.
- Press MENU – the display will show the DAC 4mA calibration factor for the instrument before returning to its standard mode of operation.

3.5 Setting 20mA Level

This calibration feature allows the instrument to simulate a condition of full-scale gas so that the 20mA output can be set. A control unit connected will indicate full-scale gas also and may enter its alarm state.

- Attach a multimeter (set to measure DC voltage) between test points TP1 and TP2.
- Select menu mode **C: 5** (refer to section 3) and press ENTER.
- Using the UP and DOWN buttons, adjust the reading displayed on the multimeter to 200mV \pm 0.5mV
- Press ENTER. Pressing MENU instead of ENTER aborts the feature.

3.6 Display mode

- Select menu mode **C: 6** (refer to section 3) and press ENTER.
- Use the UP and DOWN button to move the decimal point to the desired setting.
- Press ENTER. Pressing MENU instead of ENTER aborts the feature.
- Press MENU to return the instrument to its standard mode of operation.

Note: changing the decimal point will not result in a more accurate reading.

3.7 Display Firmware Version

The firmware version is displayed as part of the start up procedure but can be viewed without powering down the instrument via menu option 7.

- Select menu mode **C: 7** (refer to section 3) and press ENTER.
- The display will show the firmware version number.
- Press ENTER. Pressing MENU instead of ENTER aborts the feature.
- Press MENU to return the instrument to its standard mode of operation.