

CTX 300

Gas Detectors

- Quick response times
- Pre-calibrated sensor modules
- One man calibration
- Local display (optional)
- Durable in harsh environments

The detection of toxic gases or lack of oxygen requires the installation of detectors satisfying demanding requirements. The CTX 300 range is designed for all safety needs in unclassified areas.

The CTX 300 transmits the relevant data in record time, covering all hazard situations and providing extreme flexibility by way of a wide range of sensors.

Equipped with pre-calibrated sensors, display unit and adjustment devices, the CTX 300 transmitter can be maintained by one person.

Flexibility and reduced maintenance

Satisfying your safety requirements means making genuine technical breakthroughs as well as providing clear economic value.

Sensors integrating zero and sensitivity parameters are used so that maintenance is quick and safe.

The principle of the pre-calibrated sensor unit allows maintenance by a single person and significant reduction in costs.

Compliance with standards

- Compliance with European standards
- EMC in compliance with directives



Pre-calibrated sensor for easier maintenance

CTX 300

SENSOR SP

| Gas | Type of sensor | Range (in ppm) | Operating temperature | Relative humidity uncondensed |
|-------------------|-----------------|----------------|-----------------------|-------------------------------|
| O ₂ | electrochemical | 30,0% | -20°C to +50°C | 10% to 95% RH |
| | | 100% | 5°C to 40°C | 10% to 95% RH |
| CO | electrochemical | 100 | -20°C to +50°C | 10% to 95% RH |
| | | 300 | -20°C to +50°C | 10% to 95% RH |
| | | 1000 | -20°C to +50°C | 10% to 95% RH |
| | | 1,00% | -20°C to +50°C | 10% to 95% RH |
| | | 10,00% | -20°C to +50°C | 10% to 95% RH |
| CO ₂ | infrared | 1% | -30°C to +45°C | 5% to 95% RH |
| | infrared | 5% | -30°C to +45°C | 5% to 95% RH |
| | infrared | 10% | -30°C to +45°C | 5% to 95% RH |
| | infrared | 50% | -30°C to +45°C | 5% to 95% RH |
| H ₂ S | electrochemical | 30,0 | -20°C to +50°C | 10% to 95% RH |
| | | 100 | -20°C to +50°C | 10% to 95% RH |
| | | 1000 | -20°C to +50°C | 10% to 95% RH |
| NO | electrochemical | 100 | -20°C to +50°C | 10% to 95% RH |
| | | 300 | -20°C to +50°C | 10% to 95% RH |
| | | 1000 | -20°C to +50°C | 10% to 95% RH |
| NO ₂ | electrochemical | 10,0 | -20°C to +50°C | 10% to 95% RH |
| | | 30,0 | -20°C to +50°C | 10% to 95% RH |
| SO ₂ | electrochemical | 10,0 | -20°C to +50°C | 10% to 95% RH |
| | | 30,0 | -20°C to +50°C | 10% to 95% RH |
| | | 100 | -20°C to +50°C | 10% to 95% RH |
| Cl ₂ | electrochemical | 10,0 | -20°C to +50°C | 10% to 95% RH |
| H ₂ | electrochemical | 2000 | -20°C to +50°C | 10% to 95% RH |
| HCl | electrochemical | 30,0 | -20°C to +50°C | 10% to 95% RH |
| | | 100 | -20°C to +50°C | 10% to 95% RH |
| HCN | electrochemical | 10,0 | -20°C to +50°C | 10% to 95% RH |
| | | 30,0 | -20°C to +50°C | 10% to 95% RH |
| NH ₃ | electrochemical | 100 | -20°C to +50°C | 10% to 95% RH |
| | | 1000 | -20°C to +50°C | 10% to 95% RH |
| O ₃ | electrochemical | 1,00 | -20°C to +50°C | 10% to 95% RH |
| PH ₃ | electrochemical | 1,00 | -20°C to +50°C | 10% to 95% RH |
| ClO ₂ | electrochemical | 3,00 | -20°C to +50°C | 10% to 95% RH |
| Toluene | semiconductor | 2000 | -20°C to +50°C | 10% to 95% RH |
| | semiconductor | 500 | -20°C to +50°C | 10% to 95% RH |
| Trichloroethylene | semiconductor | 500 | -20°C to +60°C | 10% to 95% RH |
| Xylene | semiconductor | 2000 | -20°C to +50°C | 10% to 95% RH |
| Ethanol | semiconductor | 5000 | -20°C to +60°C | 10% to 95% RH |
| | semiconductor | 500 | -20°C to +50°C | 10% to 95% RH |
| R12 | semiconductor | 10000 | -20°C to +55°C' | 10% to 95% RH |
| R22 | semiconductor | 2000 | -20°C to +55°C' | 10% to 95% RH |
| R123 | semiconductor | 2000 | -20°C to +55°C' | 10% to 95% RH |
| R134a | semiconductor | 2000 | -20°C to +55°C' | 10% to 95% RH |
| R142b | semiconductor | 2000 | -20°C to +55°C' | 10% to 95% RH |
| R11 | semiconductor | 10000 | -20°C to +55°C' | 10% to 95% RH |
| R23 | semiconductor | 10000 | -20°C to +55°C' | 10% to 95% RH |
| R141b | semiconductor | 2000 | -20°C to +55°C' | 10% to 95% RH |
| R143a | semiconductor | 2000 | -20°C to +55°C' | 10% to 95% RH |
| R404a | semiconductor | 2000 | -20°C to +55°C' | 10% to 95% RH |
| R507 | semiconductor | 2000 | -20°C to +55°C' | 10% to 95% RH |
| R410a | semiconductor | 1000 | -20°C to +55°C' | 10% to 95% RH |
| R32 | semiconductor | 1000 | -20°C to +55°C' | 10% to 95% RH |

Other gases on request



CIFICATIONS

| Pressure | Accuracy at PA full scale | Life span (in month) | T (50) seconds | IP |
|--------------|------------------------------------|----------------------|----------------|----|
| Atm +/- 10% | +/- 1,5% | 28 | 10 | 66 |
| Atm +/- 10% | +/- 1,5% | 36 | < 20 | 66 |
| Atm +/- 10% | +/- 1,5% | 36 | 15 | 66 |
| Atm +/- 10% | +/- 1,5% | 36 | 15 | 66 |
| Atm +/- 10% | +/- 1,5% | 36 | 15 | 66 |
| Atm +/- 10% | +/- 1,5% | 36 | < 20 | 66 |
| Atm +/- 10% | +/- 1,5% | 36 | < 20 | 66 |
| Atm +/-10% | +/- 2% | 60 | 70 (T90) | 66 |
| Atm +/-10% | +/- 2% | 60 | 70 (T90) | 66 |
| Atm +/-10% | +/- 2% | 60 | 70 (T90) | 66 |
| Atm +/-10% | +/- 2% | 60 | 70 (T90) | 66 |
| Atm +/- 10% | +/- 1,5% | 36 | 15 | 66 |
| Atm +/- 10% | +/- 1,5% | 36 | 15 | 66 |
| Atm +/- 10% | +/- 1,5% | 36 | 15 | 66 |
| Atm +/- 10% | +/- 1,5% | 36 | 15 | 66 |
| Atm +/- 10% | +/- 1,5% | 36 | 15 | 66 |
| Atm +/- 10% | +/- 1,5% | 36 | 15 | 66 |
| Atm +/- 10% | +/- 1,5% | 24 | 20 | 66 |
| Atm +/- 10% | +/- 1,5% | 24 | 20 | 66 |
| Atm +/- 10% | +/- 1,5% | 36 | 15 | 66 |
| Atm +/- 10% | +/- 1,5% | 36 | 15 | 66 |
| Atm +/- 10% | +/- 1,5% | 36 | 15 | 66 |
| Atm +/- 10% | +/- 1,5% | 24 | 50 | 66 |
| Atm +/- 10% | +/- 1,5% | 24 | 50 | 66 |
| Atm +/- 10% | +/- 1,5% | 24 | 50 | 66 |
| Atm +/- 10% | +/- 1,5% | 24 | 50 | 66 |
| Atm +/- 10% | +/- 2% | 24 | 30 | 66 |
| Atm +/- 10% | +/- 2% | 24 | 30 | 66 |
| Atm +/- -10% | +/- 3% | 24 | 50 | 66 |
| Atm +/- -10% | +/- 3% | 24 | 50 | 66 |
| Atm +/- 10% | +/- 3% | 18 | 40 | 66 |
| Atm +/- 10% | +/- 3% | 18 | 40 | 66 |
| Atm +/-10% | +/- 2% | 24 | 50 | 66 |
| Atm +/-10% | +/-15% relative to alarm threshold | 18 | 20 | 66 |
| Atm +/-10% | +/-15% relative to alarm threshold | 18 | 20 | 66 |
| Atm +/-10% | +/-15% relative to alarm threshold | 18 | 40 | 66 |
| Atm +/-10% | +/-15% relative to alarm threshold | 18 | 20 | 66 |
| Atm +/-10% | +/-15% relative to alarm threshold | 18 | 20 | 66 |
| Atm +/-10% | +/-15% relative to alarm threshold | 18 | 20 | 66 |
| Atm +/-10% | +/-15% relative to alarm threshold | 18 | 30 | 66 |
| Atm +/-10% | +/-15% relative to alarm threshold | 18 | 30 | 66 |
| Atm +/-10% | +/-15% relative to alarm threshold | 18 | 30 | 66 |
| Atm +/-10% | +/-15% relative to alarm threshold | 18 | 30 | 66 |
| Atm +/-10% | +/-15% relative to alarm threshold | 18 | 30 | 66 |
| Atm +/-10% | +/-15% relative to alarm threshold | 18 | 30 | 66 |
| Atm +/-10% | +/-15% relative to alarm threshold | 18 | 30 | 66 |
| Atm +/-10% | +/-15% relative to alarm threshold | 18 | 30 | 66 |
| Atm +/-10% | +/-15% relative to alarm threshold | 18 | 30 | 66 |
| Atm +/-10% | +/-15% relative to alarm threshold | 18 | 20 | 66 |
| Atm +/-10% | +/-15% relative to alarm threshold | 18 | 20 | 66 |



CTX 300

SPECIFICATIONS

Better performance, enhanced ergonomics

Better performance

- Excellent sensitivity and signal stability
- 2 mA signal for maintenance mode
- Signal lower than 1 mA for failure mode

Clear readability

- Highly sensitive, lighted display allows local reading
- Effective power-up indication by indicator lights
- Indication of maintenance or fault function

High-Level technology

- Pre-calibrated sensor avoiding the need to use unstable gases on site for calibration purposes
- Remote sensor unit allowing measurements in even the most inaccessible places
- High-performance semiconductor type detector (detection of freon gas, etc.)

Advanced design

- Highly resistant to environmental elements
- Avoids having to use protective covers

Heavy-duty

- Use of polycarbonate and stainless steel mounting hardware
- Resistant to corrosive agents
- Durable housing

Specifically adapted options

- Removable filters, interchangeable without opening the housing (which is dust-proof, condensation-proof and water-resistant)
- Splash guard
- Gas collector cone
- Mounting brackets
- Pitot tubes, floats, heating protective device, etc.



Backlit display



Gas collector



Calibration cup



Mounting bracket



Bypass adapter

REV 0509



A wide range of sensors*

| | |
|---------------------------------|--|
| Enclosure: | Polycarbonate housing |
| Function: | Detector-transmitter |
| Display: | Highly visible backlight display unit (on option) |
| Indicator lights: | In operation: green color |
| (on CTX 300 : 3-wire) | Failure / maintenance : yellow color |
| Link: | 2 wires – CTX 300 without display unit |
| | 3 wires – CTX 300 with display unit |
| Cable inlet: | Between 6 and 11, gland PG9 |
| Power supply: | 15 to 32 V DC |
| Power consumption: | CTX 300 without display unit : 27 mA |
| | CTX 300 with display unit : 110 mA |
| | CTX 300 with display unit, for CO ₂ sensor version, or for solid states sensor versions : 100mA |
| Operating temperature: | -20°C to + 50°C |
| Sealing: | IP 66 |
| Weight: | 520 g |
| Dimensions: | 130 x 136 x 69 (lxhxd) in mm |
| Certification: | Safe area only |
| EMC: | Compliance with directives |
| Subject to operation conditions | |
| Impedance : | 32 ohms max loop for CTX300 with display unit and for solid states and CO2 sensor versions |
| | 128 ohms max loop for CTX300 without display unit |

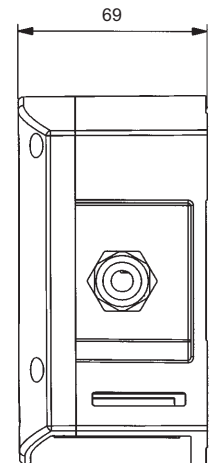
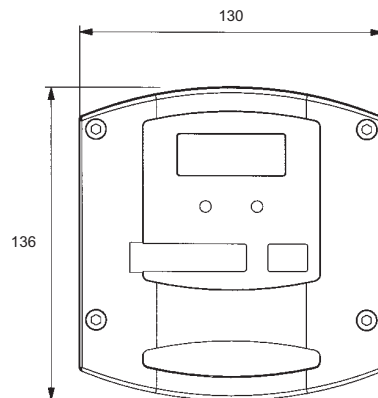

**INDUSTRIAL
SCIENTIFIC**

Cambridge Sensotec Ltd
Unit 8 Royce Court
St Ives
CAMBS
PE27 3NE
tel +44 (0)1480 462142
fax +44 (0)1480 466032
sales@cambridge-sensotec.co.uk
www.cambridge-sensotec.co.uk